

# Pressure Gage and Swichgage® Instruments

## OPL Series 4-1/2 in. (114mm) Diameter Dial

The OPL-series pressure Swichgage instruments are combination pressure indicating gages with adjustable low and high limit switches. Limit switches can be wired directly to electric pilot circuits to operate alarms, shutdown or the start/stop of engines and electric motors. Surface mount or panel mount enclosure is available for most versions. All versions feature a 4-1/2 in. (114 mm) dial for easy viewing. Adjustable limit switches are accessible from the front of the Swichgage instrument. Limit contacts have self-cleaning motion to enhance electrical continuity.

Other versions available (details on next page):

- Gage only without contacts (Murphygage instrument);
- Swichgage instrument with built-in latching relay for start-stop operations.



### Specifications

**Case:** Die cast aluminum; weatherproof

**Contacts:** See details in the Electrical section, for contact ratings.

**Dial:** 4-1/2 in. (114 mm) white on black, dual scaled psi /kPa

**Other dial configurations available. Consult factory**

**Gage Accuracy:** 2-1-2  $\pm 2\%$  for the first and last quarters of the scale, the middle half is  $\pm 1\%$ .

**Accuracy for P4 & P6 Option:**

Ranges 100 & 160 PSI; 6% full scale. 200 PSI 6-3-6. All other ranges 3% full scale

**Gearing Movement:** 302 and 304 stainless steel

**Lens:** Optically clear polycarbonate

**Pointer:** High visibility with a pointer calibration hub

**Process Connection:** Available in 1/4 NPT and 1/2 NPT. See Table B.

**Sensing Element:** Select from bronze or 316 stainless steel bourdon tube. See Table B for bourdon tube/socket combinations.



#### Product Selection Information

**WARNING:** Selection of the proper gage/Swichgage instrument should include consideration for the service application, the medium being measured, electrical ratings, hazardous area requirements and general operating conditions. Improper selection and/or application may be detrimental to the gage/Swichgage instrument and could cause failure in the operating system and possibly personal injury or property damage. If in doubt, consult our sales/engineering staff.

## Base Models

---



OPLC

### OPLC, OPLCE and OPLG

The **OPLC** is a surface mount, indicating pressure gage and switch. Adjustable high and low limit, ungrounded contacts are used to operate alarm, shutdown or start-stop circuits. Pointer closure against either of the adjustable contacts completes the pilot-duty circuit. An SPST toggle switch is provided to override the low limit contact for equipment startup. Suitable for engines or electric motors with appropriate Murphy magnetic switch or transformer relay assembly.

The **OPLCE** features a panel mount square case. It has all the features of the OPLC except the low limit contact lockout.

The **OPLG** is an indicating-only pressure Murphygage instrument. Same as the OPLC except without switch (limit) contacts.



OPLFC

### OPLFC and OPLFG

The **OPLFC** is a panel mounting version of the OPLC. It has all of the features of the OPLC except the low limit contact lockout. The lockout must be done externally through the control circuit. The OPLFC is typically used in control panels for compressors, pumps, etc. This version can be environmentally sealed with either the ES or OS options. Contact lead termination is by pigtail wires.

The **OPLFG** is an indicating only pressure Murphygage instrument. Same as the OPLFC except without switch (limit) contacts.



OPLBP

### OPLBP and OPLBPE

The **OPLBP** is a specialized version of the OPL series designed for start-stop operation of engines and electric motors. The pilot-duty limit switches are connected to an internal latching control relay for ON/OFF automation. Available for various voltages.

The **OPLBPE** is the same as the OPLBP except it has a panel mount square case.

---

## OPLC and OPLCE

**NOTE:** Does not apply to model OPLG.

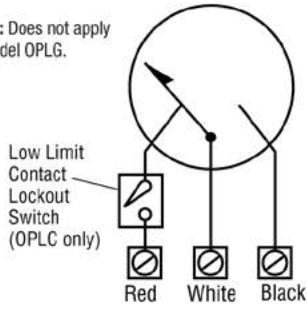

**Contact Rating:** 1 SPDT; Center off; 2 A, 30 VDC, 1 A, 125 VAC pilot duty

## OPLC, OPLCE and OPLG

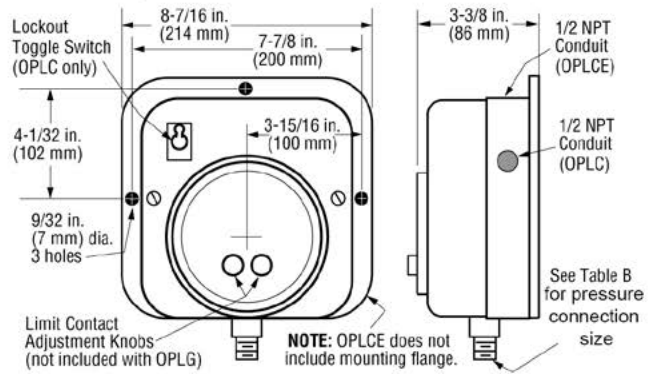

## OPLFC

**NOTE:** Does not apply to model OPLFG.

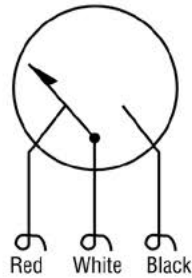

**Contact Rating:** 1 SPDT; Center off; 2 A, 30 VDC, 1 A, 125 VAC pilot duty

## OPLFC and OPLFG

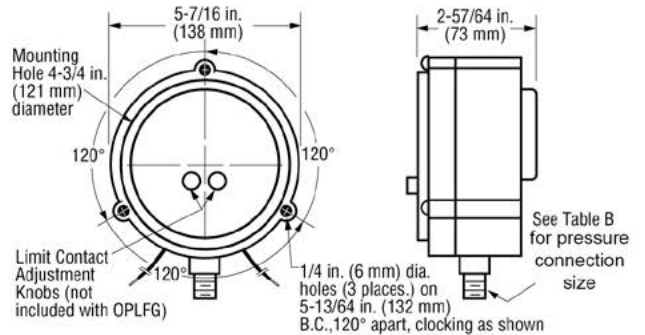

## OPLBP and OPLBPE

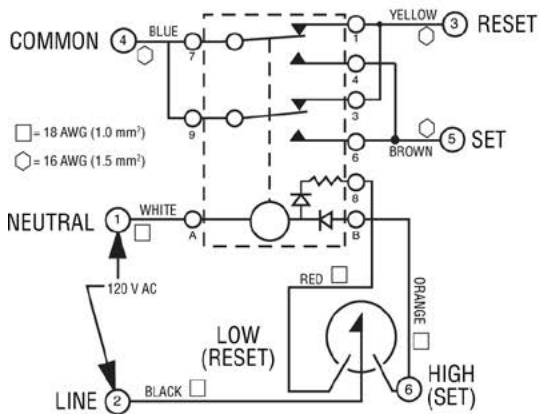

**Contact Rating:** SPDT dry relay contacts; 10 A, 125 VAC.

## OPLBP and OPLBPE

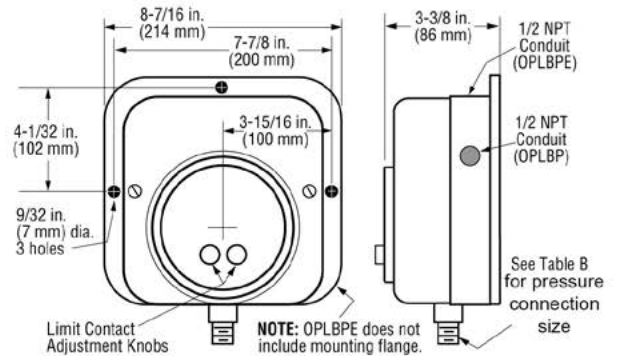

## Options and Accessories

### P4 and P6 Options

The **P4 (was PT147)** option provides a remote seal mechanism to protect the Swichgage instrument sensing element from line pressures of highly viscous and mildly corrosive fluids. Ranges are 100 through 5,000 psi (689 kPa through 34.5 MPa) [6.9 through 344.7 bar]. A sealed stainless steel capillary tube with stainless steel armor transmits the pressure from the diaphragm seal to the Swichgage instrument. Standard capillary length is 5 ft. (1.5 m). Optional lengths to 50 ft. (15 m) in 5 ft. (1.5 m) increments are available. Oil well lead lines and pumps with highly viscous liquids are typical applications. If required, customer should provide a pulsation dampener.

The **P6 (was PT167)** option is a diaphragm sealed to a 2 NPT housing which attaches directly to the pressure gage connection. The gage sensing element and the diaphragm chamber are filled with a silicone fluid so that pressure against the diaphragm causes the gage to respond. The diaphragm housing is plated machined steel. Typical application is for oil well lead lines. Ranges are 100 through 1,000 psi (689 kPa through 6.8 MPa) [6.89 through 68.9 bar]. The P4 and P6 can be ordered as optional features to the Swichgage or indicating-only Murphygage instrument. See *How to Order*.

**NOTE:**  
P4 option not available for scales below 100 psi.  
P6 option available for scales 100 psi thru 1,000 psi only.



**OPLFC-A-600-OS-P6**



**OPLFC-A-1000-OS-P4L**

### Tamper-proof Contact Accessory

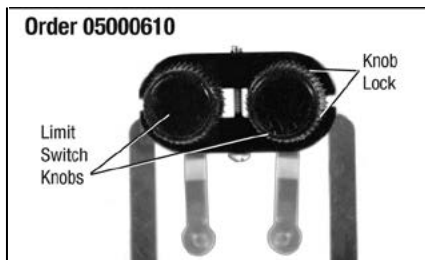

### Pulsation Dampener

- Eliminate pointer contact flutter on pressure Swichgage and Murphygage instruments which are subject to pulsating pressure from reciprocating pumps or compressors.
- Allow close high-low contact settings for more accurate pressure indication and equipment control.
- Decrease wear on internal geared movement and increase the life of your instrument by eliminating excessive strain and unnecessary pointer movement.
- Available in brass, carbon steel and stainless steel.
- **Must be ordered separately.**



# How to Order

Options listed below. All configurations may not be available. Call your sales representative or Enovation Controls for more information.

## Selecting a Model:

**OPLBP - S - 2 - 1000 -**

1. Select a Base Part Number from Table A \_\_\_\_\_
2. Select Bourdon Tube and Socket code from Table B \_\_\_\_\_
3. Select BP Relay Voltage code (applies to BP models only) from Table C \_\_\_\_\_
4. Select Range code from Table D<sup>1</sup> \_\_\_\_\_
5. Select Options from Table E<sup>2</sup> \_\_\_\_\_

1 - For metric only dials specify scale and unit of measure; example: kPa or bar.

2 - List options in alphabetical order (A to Z) followed by numeric in ascending order. Place a dash (-) between each option. See example above.

**Table A: Base Models**

Model	Description
OPLC	Swichgage, surface mount, with low limit lockout switch
OPLCE	Swichgage, panel mount square case
OPLFC	Swichgage, panel mount
OPLBP*	Swichgage, surface mount, with latching control relay
OPLBPE*	Swichgage, panel mount square case, with latching control relay
OPLG	Murphygage, surface mount
OPLFG	Murphygage, panel mount

\*This version not covered by the CE mark.

**Table C: BP Relay Voltage**

Code	Voltage
Blank <sup>3</sup>	120 VAC
2	12 VDC
4	24 VDC

NOTE: Relay Voltage applies to BP models only.  
3: No code is required for 120 VAC voltage.

**Table B: Bourdon Tube and Socket**

Code	Process Connection	Tube Type	Range Selection Limits psi (MPa) [bar]	Bourdon Tube and Tip Material (all joints TIG welded except A)	Socket Material
A <sup>4</sup>	1/4 NPT	Drawn C-Tube	Through 1,000 psi (6.89 MPa) [68.95 bar]	Grade A Phosphor Bronze Tube (Brass Tip, Silver Brazed)	Brass
S <sup>5,6</sup>	1/4 NPT	Drawn C-Tube	Through 1,000 psi (6.89 MPa) [68.95 bar]	316 Stainless Steel	316 Stainless Steel
	1/2 NPT	Drawn Helical	1,500/10,000 psi (10.3/68.9 MPa) [103.42/700 bar]		

<sup>4</sup>Standard through 1,000 psi (6.89 MPa) [68.95 bar]  
<sup>5</sup>Standard 1,500 psi (10.3 MPa) [103.42 bar] through 10,000 psi (68.9 MPa) [700 bar]  
<sup>6</sup>Optional all ranges

Table D: Ranges			
Code	Vacuum/psi	kPa/MPa	bar
30HV60H	30" Hg/Vac-60" Hg/Press.	-101 kPa-203 kPa	-1.01-2.03
30V	30" vac-0 psi	-101 kPa-0 kPa	-1.01-0
30V15	30" vac-15 psi	-101 kPa-103 kPa	-1.01-1.03
30V30	30" vac-30 psi	-101 kPa-207 kPa	-1.01-2.07
30V100	30" vac-100 psi	-101 kPa-689 kPa	-1.01-6.89
30V200	30" vac-200 psi	-101 kPa-1.38 MPa	-1.01-13.79
30V300	30" vac-300 psi	-101 kPa-2.07 MPa	-1.01-20.68
15	0-15 psi	0-103 kPa	0-1.03
30	0-30 psi	0-207 kPa	0-2.06
60	0-60 psi	0-414 kPa	0-4.13
100	0-100 psi	0-689 kPa	0-6.89
160	0-160 psi	0-1.10 MPa	0-11
200	0-200 psi	0-1.38 MPa	0-14
300	0-300 psi	0-2.07 MPa	0-20
400	0-400 psi	0-2.76 MPa	0-28
600	0-600 psi	0-4.14 MPa	0-40
1000	0-1000 psi	0-6.89 MPa	0-70
1500	0-1500 psi	0-10.34 MPa	0-100
2000	0-2000 psi	0-13.79 MPa	0-140
3000	0-3000 psi	0-20.68 MPa	0-200
5000	0-5000 psi	0-34.48 MPa	0-350
10000	0-10,000 psi	0-68.95 MPa	0-700

**Dials**  
All dials are dual scaled psi and kPa/MPa. Single scale dials and custom dials available. Additional charges may apply.

**Gages**  
All 4-1/2 inch (114 mm) Swichgage instruments are available for Class I, Division 1, Groups C & D hazardous applications.

Division 2 locations can also be covered by our Non-Incendive or Intrinsically Safe systems. Contact any Enovation Controls representative for complete details.

Table E: Options <sup>7</sup>			
Option	Description	Option	Description
BC	Back connected bourdon tube	P6	(PT167) PT167 pressure transmitter, direct mounting
ES	Environmentally sealed	TA	(TCA) Tickler contact
EX	Explosion-proof: Swichgage® enclosed within explosion-proof case; Class I, Div. 1, Groups C & D		
EL	(EXLC) Explosion-proof less case		
LC	Less case		
OS	Oil sealed case		
P4L	(PT147) Pressure transmitter with 5 ft. (1.5m) capillary* (Pulsation dampener no longer supplied.) *For capillary greater than 5 ft., specify in 5 ft increments following designator; example: P4L15		

<sup>7</sup> Options not available on all models or configurations.

## Shipping Information\*

### Shipping Weights:

OPLC: 5 lbs 9 oz (2.5 kg)  
 OPLG: 5 lbs 6 oz (2.4 kg)  
 OPLFC and OPLCE: 3 lbs 4 oz (1.5 kg)  
 OPLFG: 3 lbs 4 oz (1.5 kg)  
 OPLBP and OPLBPE: 5 lbs 11 oz (2.6 kg)

### Shipping Dimensions:

OPLC, OPLG and OPLFG:  
 9-1/2 x 9-1/4 x 5-3/4 in. (241 x 235 x 146 mm)  
 OPLFC and OPLCE:  
 9-1/4 x 8-1/4 x 5-1/2 in. (235 x 210 x 140 mm)  
 OPLBP and OPLBPE:  
 9-1/4 x 8-1/4 x 5-1/2 in. (235 x 210 x 140 mm)

\* Some options could alter shipping weights and dimensions. Consult factory.