

Keystart 7210/7211

Engine and Generator Control Modules



Description

Keystart 7210 and 7211 control modules provide manual start/stop and automatic fault protection for generators, pumps and other engine-driven applications.

Operator control is by a 3 position keyswitch. The key is common to all Keystarts and removable only in the Stop/Reset (O) position. Outputs are provided for the control of engine fuel (energized to run), starter motor and preheat. The Keystart also has an alarm output for remote/audible warning of faults.

Indication of engine status and faults is by six LEDs and icons. Fault shutdown switch inputs (closing to negative on fault) are provided for engine low oil pressure, high engine temperature and auxiliary/plant fault. Model 7211 has a fully adjustable engine overspeed shutdown, driven by generator AC or magnetic pickup. Charge alternator excitation and a charge fail warning LED are fitted as standard.

Electrical connection is by quick-connect, spring-clamp terminal blocks. A universal 7 to 30VDC power supply allows operation with 12 or 24VDC engine batteries, with engine crank-dip voltage protection fitted as standard.

Keystarts are front-of-panel mounted through a standard square cut-out, and secured at the rear with two mounting clips.

Warranty

A two year limited warranty on materials and workmanship is given with this product. Full details are available at www.fwmurphy.co.uk/warranty

- Manual start/stop
- Keyswitch operation
- Timed preheat output
- Automatic fault shutdowns
- Overspeed shutdown, magnetic pickup or generator AC driven
- Front-of-panel mounted

Product specifications

power supply:	
operating voltage:	
steady state	7 – 30 VDC
brown out / cranking	5 VDC
current consumption	< 100mA
inputs:	
fault switch inputs:	close to negative DC during fault
–ve input defined as:	–1V to +1V w.r.t. – ve DC supply
speed sensing inputs:-	
generator AC	70 – 270 VAC rms, <50 to >60 Hz. default setting: 50 or 60 Hz
mag pickup/transducer	3.5 – 21 VAC rms, <2000 to >6500 Hz.
outputs: <i>(all ratings non-reactive)</i>	
run (fuel), preheat	positive DC, switched NO relay contact, 1 A max. @ 24V DC
start (crank)	positive DC via keyswitch contacts, 16 A max. @ 24V DC
alarm (fault)	negative DC (open collector NPN transistor), 100mA max.
speed calibration	to suit 0 – 1 mA, 75 Ohm meter output = 0.75mA at rated engine speed
adjustable settings:	
preheat timer	0 to 20 secs, default setting 0 secs
fault override timer	2 to 20 secs, default setting 10 secs
overspeed trip level	100 to 130 % of calibrated speed, default setting 110%
general:	
overall dimensions (w x h x d)	72 x 72x 100 mm / 2.83 x 2.83 x 3.94 in.
panel cut-out size	DIN 68 x 68 mm / 2.68 x 2.68 in.
weight	approx 300 g / 0.7 lb
operating ambient temperature	–10 to +55°C / 14 to 131°F

Front view and operation

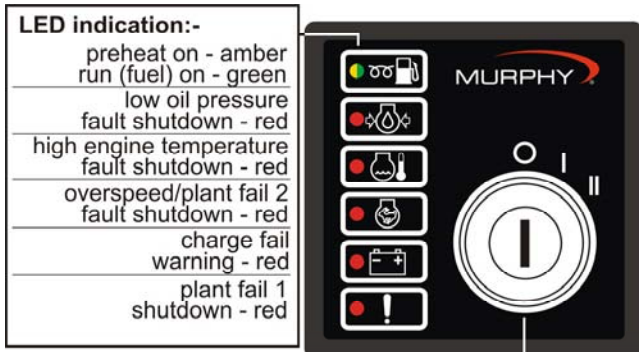

Rear view, connection and settings

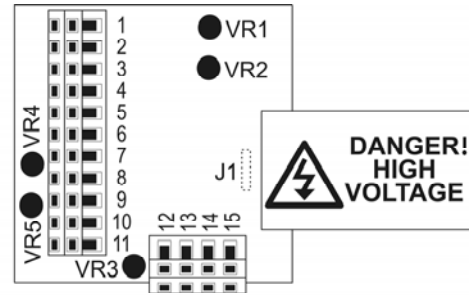

Connection:-

- | | |
|----------------------------------|---------------------------------|
| 1 Alarm output: -DC, 100mA | 9 Engine temp fault input |
| 2 Fuel output: +DC, 1A | 10 Charge fail (WL) |
| 3 Preheat output: +DC, 1A | 11 Speed calibration output + |
| 4 Start (crank) output: +DC, 16A | 12 Speed calibration output - |
| 5 +ve DC power supply | 13 L Gen. AC (7211 only) |
| 6 -ve DC power supply/pickup | 14 N 70 - 270 VAC, 50/60Hz |
| 7 Plant fail 1 input | 15 Plant fail 2 input (7210) or |
| 8 Oil pressure fault input | Mag. pickup input (7211) |

Adjustment (use a 3mm flat head screwdriver)

All units:-

VR1: Preheat, 0 - 20 secs, clockwise to increase.

VR2: Fault override, 2 - 20 secs, clockwise to increase.

Overspeed (7211) units only:-

VR3: Overspeed, 100 - 130% of VR4/5, clockwise to increase.

VR4: Generator AC Speed calibration. Set link J1. Run engine.

VR5: Mag. pickup Adjust pot. to give calibration output of 0.75mA.

How to order

Stock code Model / description

76.70.1166 KEY7210 Keystart, no overspeed

76.70.1167 KEY7211 Keystart, AC/MPU overspeed*

* Note: stock units are set to AC sensing, nominal 50Hz. To select magnetic pickup sensing, adjust internal circuit board link J1.

Further information

Document Description

00-02-0678 Keystart 7210/9610 series installation

Typical connection

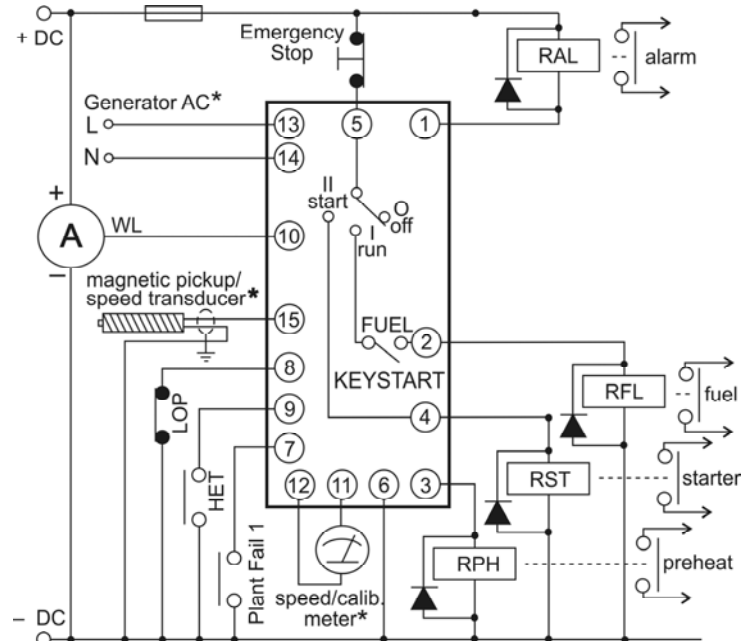

Notes:-

* Overspeed models 7211 only. Selection of generator AC or magnetic pickup speed sensing is by internal circuit board link J1. Stock units are set for generator AC sensing, 50Hz nominal. On non-overspeed models, pin 15 is 'plant fail 2' switch input, with connection as pin 7.

FW MURPHY

P.O. Box 470248, Tulsa, Oklahoma 74147 USA
+1 918 317 4100 Fax: +1 918 317 4266
E-mail: sales@fwmurphy.com

INDUSTRIAL PANEL DIVISION

Fax: +1 918 317 4124
E-mail: ipdsales@fwmurphy.com

MURPHY POWER IGNITION

Website: www.murphy-pi.com

CONTROL SYSTEMS AND SERVICES DIVISION

P.O. Box 1819, Rosenberg, Texas 77471 USA
Phone: +1 281 633 4500 Fax +1 281 633 4588
E-mail: css-solutions@fwmurphy.com

FRANK W. MURPHY LTD.

Church Road, Laverstock,
Salisbury, SP1 1GZ, United Kingdom
Tel: +44 1722 410055
Fax: +44 1722 410088
E-mail: sales@fwmurphy.co.uk
Web: www.fwmurphy.co.uk

COMPUTRONIC CONTROLS

41 - 43 Railway Terrace, Netchells,
Birmingham, B7 5NG, United Kingdom
Tel: +44 121 327 8500
Fax: +44 121 327 8501
E-mail: sales@computroniccontrols.com
Web: www.computroniccontrols.com

FW MURPHY INTERNATIONAL TRADING (SHANGHAI) CO., LTD.

Suite 1704, Tower B, City Center of Shanghai, 100 Zunyi Road
Shanghai, 200051, China
Phone: +86 21 6237 2082 Fax +86 21 6237 2083
E-mail: mhong@fwmurphy.com

FW MURPHY INSTRUMENTS (HANGZHOU) CO., LTD.

77 23rd Street, Hangzhou Economic & Technological Development Area
Hangzhou, Zhejiang, 310018, China
Phone: +86 571 8788 6060 Fax: +86 571 8684 8878



USA-ISO 9001:2000 FM 28221
UK-ISO 9001:2000 FM 29422
Registered Facilities

