



High Country Tek, Inc.

## HGC-2 Initial Installation Guide

Electronic Control Solutions for the Global Fluid Power Industry



Beware of HIGH VOLTAGE when operating any generator system – high voltage can be LETHAL – observe ALL laws, by-laws and health & Safety recommendations for your immediate location, state and/or country.



**WARNING**  
HIGH VOLTAGE  
Voltage:  
2 seconds to 1000  
and/or 1000V

### HGC-2 Product Features:

- Full PID closed loop speed controller for use with AC generator systems
- Customer selectable voltages and frequencies for global applications
- Operates with all major OEM electro-hydraulic valve and pump equipment
- Industry standard Deutsch 12 way connector protected to >IP69K ( NEMA 6P )
- Environmentally hardened by 'Solid' potting with flame retardant materials
- Full CE compliance for confident global application on all mobile equipment
- Comprehensive on-line literature, manuals, user guides and application information
- Fully configurable by PC based user interface for set-up and diagnostics
- Fast, easy and reliable development-to-production timeline across multiple platforms
- U.S.A. designed, built and supplied

## Application Hints & Tips:

### ALWAYS do the following:

- Take a few minutes to FULLY read THESE information / data sheets BEFORE starting.
- Isolate this unit from all other equipment BEFORE any form of welding takes place.
- Isolate this unit if ANY form of battery charging or boosting takes place on the vehicle.
- Isolate this unit if ANY form of alternator 'load dump' testing takes place.
- Keep ALL High Voltage AC cables separate from Low Voltage DC cables.
- Make sure the module supply voltage is correct and connected.
- Ensure correct fuses are used and replaced with correct value to avoid system damage.
- Ensure that you are aware of the adjustments and consequences on the electronics
- Make sure you have the correct tools to do the intended job ( i.e. P.C., software ) etc.
- Check ALL connections to and from this unit to ensure NO short or OPEN circuits.
- Check the units supply voltage is CORRECT, ' ELECTRICALLY CLEAN ' and STABLE.
- Operate the units within specified operating temperature for best & reliable performance.
- Ensure that any unused wires / terminals are terminated safely and not shorted together.
- Ensure ALL connectors are wired correctly, secure and locked in place.
- Observe the set-up procedures in this manual for best operational results.
- ALWAYS follow and abide by local and country health & safety standards.
- ALWAYS protect yourself and consider others !

### NEVER do the following:

- **Arc Weld or Charge Batteries with this driver unit connected as damage can occur.**
- Use this unit if you are unsure of electrical OR hydraulic connections or expected operation
- Use this unit in Areas where other AC or DC coils **HAVE NOT** been fully suppressed.
- Use a power supply that is not rated for the correct required O/P current under full load.
- Allow wires TO or FROM the unit to short circuit ( to each other or chassis/cabinet e.t.c. ).
- Attempt to use this unit in areas of intense RF without adequate screening measures.
- Disconnect or connect wires to or from this unit unless it isolated from the power supply.
- Use this unit in temperatures that exceed those specified as operation may be effected.
- Start this unit without ensuring ALL work areas are clear of personnel !



Hydraulic generators can produce LETHAL voltages when operating.  
Remember to abide by all health and Safety rules and keep yourself and work colleagues safe !



**HGC-2 Connection Information:**

<b>Input Supply Voltage:</b>	9 – 28VDC ( Absolute Maximum )	<b>Housing Type:</b>	HCT unique ‘encapsulated’ block.
<b>Input Supply Current:</b>	Valve Current Setting + 50mA Quiescent (Max)	<b>Housing Material:</b>	ABS, black
<b>Feedback Voltage:</b>	100 to 250VRMS	<b>Encapsulation:</b>	Flame resistant potting compound
<b>Feedback Frequency:</b>	50 or 60Hz with +/-3Hz adjustment	<b>Wire Connections:</b>	8 pin Deutsch - DTS06 - Male
<b>O/P Current Ranges:</b>	600mA, 1.2A or 2.5A	<b>Mounting:</b>	2 x No. 6 ( 4mm ) screws .
<b>Dither Frequency :</b>	Software adjustable, ~50Hz to ~1KHz	<b>Operating System:</b>	Windows® XP Professional / Vista
<b>Temperature range:</b>	-20 to +80 °C ( operational )	<b>Unit Settings:</b>	All by PC user interface
<b>NEMA/IP Rating:</b>	NEMA 6 / 67 ( module only )	<b>Certifications</b>	CE

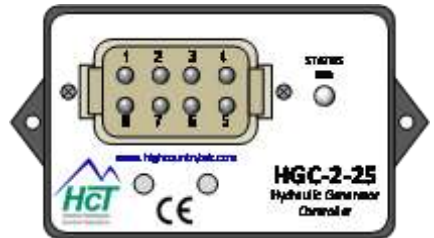
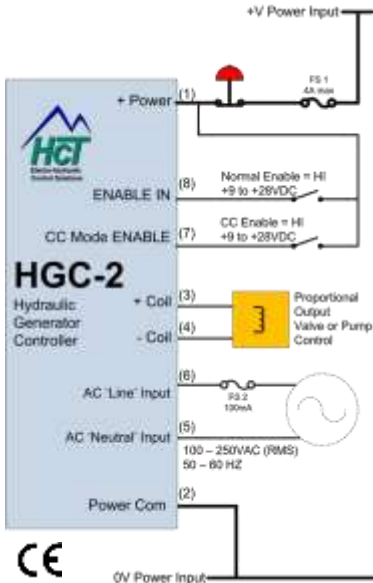

Pin	Function
1	+VDC Input Supply
2	0VDC Input Supply
3	+Solenoid Connection O/P
4	-Solenoid Connection O/P
5	AC feedback Neutral I/P
6	AC feedback Line I/P
7	Constant Current Mode enable I/P
8	Controller ENABLE I/P



**For CE compliance, do the following:**

- 1) Mount the controller to a grounded steel plate.
- 2) Use shielded twisted pair and connect the shield to ground (only on one end) for the following connections: +VDC with 0VDC (pins 1 & 2), +Solenoid with – Solenoid (pins 3 & 4), AC Neutral with AC Line (pins 5 & 6), and Constant Current enable with Controller Enable (pins 7 & 8).

## Graphical User Interface:



## Typical Initial Test Configuration:

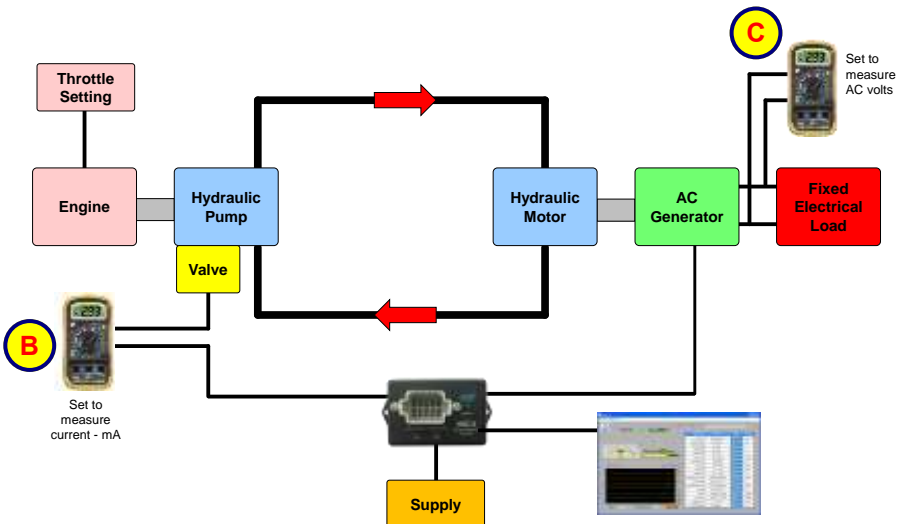



## Controller Set-up: PID Tuning

### System Repeatability & Stability:

Run Open loop using CC ( Constant Current ) mode

- 1) Set fixed current value for CC mode test using GUI and entering mA level at **A**
- 2) Connect meter as shown in **B** – measuring DC valve current in mA.
- 3) Connect fixed load to generator – non voltage/frequency dependent ( i.e. heater element )
- 4) Connect meter as shown in **C** to measure generator AC voltage output
- 5) Set engine throttle to fixed, steady position ( i.e. high idle )
- 6) Close 'Normal Enable' and 'CC mode enable' switches together
- 7) Now Open the enable CC mode switch – leave Normal Enable switch closed
- 8) Allow readings to settle and measure/note current to valve coil
- 9) Allow readings to settle and measure/note generator output voltage
- 10) Open the HGC-2 'Normal Enable' switch
- 11) Meter reading output current to valve in 8) should go to near zero
- 12) Meter reading generator voltage will reduce or collapse to near zero
- 13) Repeat steps 6-10, x5 times, noting valve DC current and generator AC voltage readings
- 14) Look for DC valve current to be within +/- 10 mA each time if not bleed system
- 15) Look for generator AC voltage to be within +/- 10% each time

#### NOTES:

- ❖ If readings are repeatable and stable when running, proceed to tuning the PID for closed loop speed control.
- ❖ If readings are **NOT repeatable** or system hunts, do the following:

### Reasons for instability:

Item	Problem	Action
Air	Causes oscillations in valve/pump control and repeatability issues	Bleed valve, pumps, hoses & system at highest point.
Hoses	Acts like accumulator and causes spongy operation / hunting / of system	Reduce hose length, higher number of wires in hose, replace with solid piping
Oil	Viscosity changes due to age and heat	Cool the oil if needed to maintain constant temperature.
Leaks	Loose fittings, worn 'O' rings, porosity	Replace parts as needed, tighten fittings and bolts e.t.c.

## Controller Set-up: PID Tuning



### Initial explanation of operation:

1. See red outlined box above for location of setting described above:
2. The PID loop time sets the number of cycle periods averaged between PID samples.
3. The adjustment range is from 1 to 30 cycles - default setting is 8
4. 'Cycle Period' is the reciprocal of the frequency x 2 ( internal multiplication for accuracy ) which is 120 for a generator O/P frequency of 60Hz
5. Corrective action sample rate at 60Hz is determined by:  $1/(1/120 * 8) = 15\text{Hz}$
6. This means we sample the O/P frequency 15 times/Sec and correct speed as needed.
7. A larger number of cycles, i.e. >8 will slow the controller response rate but will average out any noise better because more samples are being used in the calculation.
8. A smaller number of cycles i.e. <8 PID loop time cycle will increase the controller response rate but could also be more susceptible to instability due to larger changes caused when a noisy or unexpected cycle is included in the calculation.
9. Changing the loop time will change the system's response to the PID settings.
10. If the loop time is changed during 'fine-tuning', the PID setting sequence should be repeated.

### Oscillation:

In this instance the term 'Oscillation' describes the output frequency of the generator as it 'wanders' or 'hunts' around the 'Target Frequency' and means that it is not 'locked-on-target-frequency' and stable. This issue can be clearly heard, and is typically caused by the pump being stroked and de-stroked. The output frequency can be viewed on the PC Graphical user interface in the graphing section.



## Controller Set-up: PID Tuning

### Tuning the PID loop on the HGC-2-XX:

The HGC-2-XX has a true Proportional (P), Integral (I) and Derivative (D) closed loop correction system built into it for maximum accuracy speed control and load correction.

The 'P', 'I' and 'D' values (coefficients) can be adjusted from 0 to 100% in each case .

1. Enter the **Target Frequency** the controller will maintain - 50 or 60Hz
2. Use **Frequency Adjustment** to trim O/P frequency if needed ( +/-3Hz in 0.1Hz increments )
3. Enter the **Min** and **Max current** range of the valve or pump coil into the boxes.
4. Enter the **Min Frequency** allowed by your application.
5. Enter the **Max Frequency** allowed by your application.
6. Set the dither to the valve dither required in the valve literature. 140 Hz is a good starting point for most valves and pumps. Too much dither will cause the spool to go unstable, too little and the response will be slow.
7. Start the tuning sequence with the 'I' and 'D' values set to zero (10)
8. Set the 'P' value set to an initial small number (~50).
9. To test these preliminary settings, and get a feel for the system response, changes in demand should be triggered by changing the AC load on the generator output or the pump speed by changing the prime mover RPM ( throttle position ) .
10. Watch the generator output frequency after each change occurs in the GUI graphing section.
11. If the frequency is oscillating around the setpoint, the 'P' value is too high.
12. If the frequency is not achieving the setpoint (over or under) the 'P' value may be too low.
13. Adjust the 'P' value up until oscillation starts to occur, then reduce it just enough to stop the oscillation.
14. Remember to repeat step 3. After any changes in the 'P' setting to ensure stability. Ensure changes are made over the whole oil temperature range expected to be seen in the application as viscosity can affect system stability at this early stage.
15. At this point, the generator frequency will potentially not always achieve the Target frequency setpoint after every change in AC load on the generator output or pump speed is made as the controller is only using the 'P' setting – this is normal.
16. Now, introduce changes again and start to increase the 'I' setting just enough to allow the frequency to achieve the Target frequency setpoint after every change to the AC load on the generator output or the pump speed.
17. If the 'I' setting is too high, oscillations will occur.
18. If the I setting is to low, the target frequency will not be reached as in 9.
19. Once the generator is stable and responding well to changes in generator load or pump speed, the 'D' setting can be increased to allow the closed loop controller to limit the generator output frequency over and undershoot during AC load or pump speed changes.
20. If the 'D' setting is too high, oscillations can start to occur.
21. Once the 'D' setting has been made, the user should once again apply as many load and speed changes as possible to simulate the applications intended operating situations.
22. If the frequency oscillates or is not stable, the procedure above may need to be repeated to 'fine-tune' the system.

**End of PID tuning section.**



## Controller Set-up: Modes & Adjustments

### CC – Constant Current Mode:

This mode is used to verify the system is stable under a constant command signal. The current mode would be set to any level in the control range of the valve or pump. By commanding the system with a constant signal, there should be no oscillation and the system should remain stable. If not, there may be a problem with the hydraulics or a mechanical problem. This can be used as a starting point to check the system before tuning. If the user cannot get the system stable, the hydraulics may be the cause and a full overview of all hydraulic components, their settings, the circuit and the installation should be undertaken.

### Min and Max Frequency:

The Min and Max Frequency setting is set to the Low and High end of the frequency and will trigger an alarm (Fault). Set this at the point where an alarm or shutdown is necessary.

Alarm Actions:

Set the condition of the alarm, no fault or Fault

Set the time allowed before the alarm triggers, this is necessary to allow the controller to fault for very short periods of time and not trigger an alarm on every overshoot or undershoot.

### Ramp Up and Ramp Down:

Set the time of ramp by mA/second. Too slow and the controller may not respond in time, too fast and the controller may become unstable.

NOTE: Ramps are only functional when the controller is powered up. To use the ramps on start – up or shut down, power the controller up on Pin # 1 always, and use the enable/disable (Pin # 8) to shut down the generator. The ramps will work only when the controller is powered on Pin # 1.

End of Procedure.

## Need More Information ?

For the latest company and product information, visit us at [www.hctcontrols.com](http://www.hctcontrols.com) or for customer service, pricing, order placement and application support, contact us through E-mail at : [info@hctcontrols.com](mailto:info@hctcontrols.com)



This data sheet may contain mistakes and printing errors. The information in this publication is regularly checked and corrections made in the next issue. Please check our website for latest version. HCT accepts NO liability for technical mistakes or printing errors, or their consequences.

**High Country Tek, Inc.**

208 Gold Flat Court  
Nevada City, CA, 95959  
Tel: (1) 530 265 3236  
Fax:(1) 530 265 3275

