

Autostart AS710S Generator Controller V1.00 – V1.09(a)

mi5262
revision E, 19th June 2002
catalogue section 75

Installation Instructions

Section A: Installation and Wiring



Please read the following information before installing. A visual inspection of this product for damage during shipping is recommended before installation. It is your responsibility to ensure that qualified mechanical and electrical technicians install this product. If in doubt, please contact your local Murphy representative.

GENERAL INFORMATION

WARNING

BEFORE BEGINNING INSTALLATION OF THIS MURPHY PRODUCT

- ✓ Disconnect all electrical power to the machine
- ✓ Make sure the machine cannot operate during installation
- ✓ Follow all safety warnings of the machine manufacturer
- ✓ Read and follow all installation instructions

Description

The Autostart AS710S is part of the AS7XX family of controls, designed for use in the automatic or manual control of a standby diesel generator, pump or other engine driven equipment. The unit features over 50 programmable options - timers, inputs, outputs, control options and fault protections - allowing it to be used in a wide variety of engine applications.

Operator control is by a 3 way keyswitch (off, auto and manual), with a back-lit liquid crystal display (LCD) for indication of plant status, measured parameters and fault conditions. All units features a communication port, providing optional monitoring, control and programming from Murphy software (running on a local or modem connected PC).

The AS710 is designed for front of panel mounting through a DIN standard 92 mm (3^{5/8}") square aperture. Electrical connection is at the rear, via a pair of two-part type screw terminal blocks.

This document details the panel installation and electrical connection of the AS710S fitted with firmware versions V1.00 - V1.09(a) (standard models as detailed opposite). Additional information on the operation, specification and programming of the AS710 and AS7xx family of controls may be found in the following documents:-

Doc. ref.	Title
ms5259	AS710 bulletin and specification
mi5265	AS7xx installation section B: programming
mi5266	AS7xx and AS7CK PC software

The above information is available on request from your Murphy representative, or from the 'products' section of our website www.fwmurphy.co.uk



Familiarisation

Unpacking

Each AS710 is supplied complete with:-

- 2 terminal blocks (connected into the rear of the unit)
- 2 keys
- 2 mounting clamps
- these instructions

Model numbers

The model variation is labelled on the top side of each unit (as shown overleaf), and should be checked before installation to ensure compatibility with the application.

Standard models are:-

<i>Model</i>	<i>Description</i>
AS710SKCA	AS710S, 110VAC nominal voltage, sender type oil pressure and temperature inputs
AS710SKDA	As above, but 230VAC nominal
AS710SKCB	AS710S, 110VAC nominal voltage, switch type oil pressure and temperature inputs
AS710SKDB	As above, but 230VAC nominal

Special build variants have a numbered suffix in the model reference e.g. AS710SKDA/001. For full details of special models, please contact your Murphy representative.

GENERAL INFORMATION (cont.)

Familiarisation (cont.)

Front Facia



32 character, back-lit LCD
(Liquid Crystal Display)

3 position operating mode
keyswitch:-
 Off/reset
 Auto
 Manual

Rear Facia

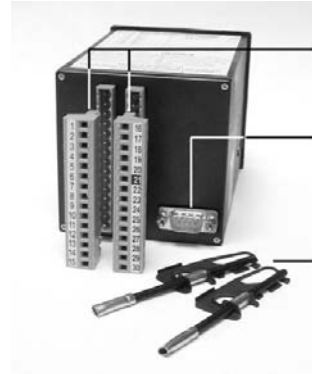

2 x 15 way, two-part
connectors, numbered 1 - 15
and 16 - 30

Communication port

Mounting clamps x 2

Top Facia Labelling

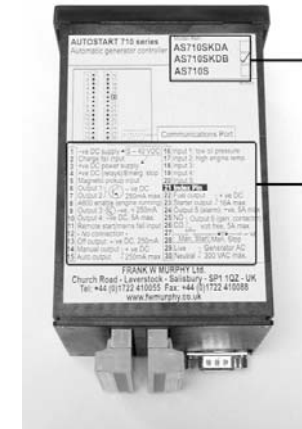

Model reference

Electrical connection details

Specifications

Power supply:	
Operating voltage: steady state range crank brown-out	5 to 40 V DC continuous to 0V for <= 100 mSec typically 150 mA
Current consumption	
Inputs:	
DC inputs (inputs 1 - 5, remote star positive input voltage range negative input voltage range	80% to 100% of battery +ve -1V to +2V from battery -ve
Generator AC input:- operating voltage range frequency measurement range	90 to 300 V AC rms 0 to 99 Hz.
Magnetic pickup:- operating voltage range frequency measurement range	7 to 80 V AC rms 0 to 10 kHz
Outputs:	
	<i>(all ratings for resistive load)</i>
Start and fuel relays	+ ve DC (switched SPNO contact rated 16A max. @ 24V DC
Programmable outputs 1 to 3	- ve DC (open collector transistor) rated 250mA max. @ 33 VDC
Programmable output 4	- ve DC (switched SPNO contact) rated 5A max. @ 24V DC
Programmable output 5 (default setting: Common Alarm	+ ve DC (switched SPNO contact rated 5A max. @ 24V DC
Programmable output 6 (default setting: Gen. contactor)	volt free SPNO contacts rated 5A max. @ 240V AC
Auto & Manual outputs	+ ve DC, 250mA max.
Off/reset output	- ve DC, 250mA max.
Physical:	
Overall dimensions (W x H x D)	96 x 96 x 162 mm
Panel cut-out size	DIN standard 92 x 92 mm
Weight	approx. 710 g
Operating ambient temperature	-10 to +55 °C
Case sealing	IP22

INSTALLATION INFORMATION

Panel Mounting

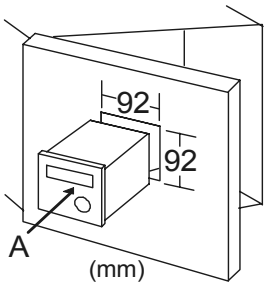

The AS710 is mounted in the front of a control panel through a DIN standard aperture, 92 mm (3⁵/₈" square.

With the mounting clamps removed, insert the unit through the front of the panel cut-out (A).

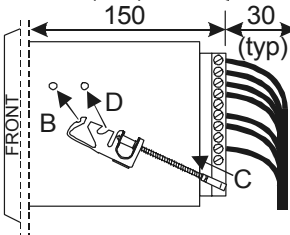

The case extends to 150mm (6") behind the panel front; an extra 30mm (1.25") minimum should typically be allowed for the connection of the wiring harness.

Working behind the panel front, fit both mounting clamps to pairs of studs on each side of the case. Locate the clamp on to the front stud (B), compress the clamp by pushing on the screw (C) and push the clamp upwards to locate on to the rear stud (D).

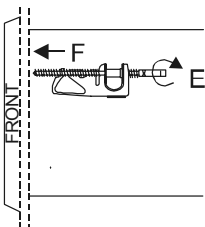

With both clamps fitted, tighten the screwed pins (E) so that they move forward and secure the unit to the rear of the panel fascia (F). Panel thicknesses of up to 8mm can be accommodated.

Programming

The AS710 has over 50 programmable features, including settings for timers, trip levels, alarms and control options. These **MUST** be programmed correctly before the Autostart can be tested or used to control an engine.

WARNING: Failure to correctly program each unit can result in damage to Autostart, engine and other equipment.

The AS710 can be programmed in one of two ways:-

- 1) Hand held programmer/keypad model AS7PROG may be connected into the rear of the unit:-

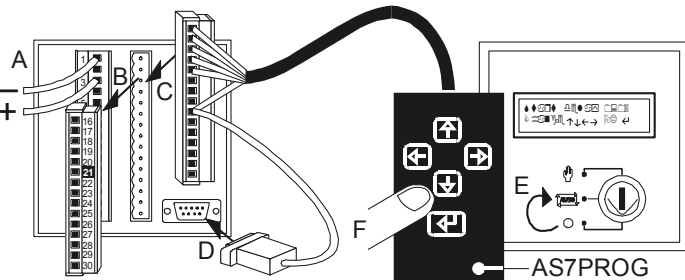

- A. Switch Autostart to O (OFF), and connect the DC power supply (negative to pin 1, positive to pin 3)
- B. Remove terminal block 16 - 30
- C. Connect AS7PROG terminal block into socket 16-30

- D. Insert the AS7PROG D-connector
- E. Switch unit to AUTO
- F. Enter PIN if prompted (factory default is '1234')
- G. Use the keypad and Autostart display to step through and edit program options.

- 2) Alternatively, use Murphy PC software model AS7CK. This allows program 'profiles' to be created, edited and downloaded to the AS710 over a communication link, quickly and error free. The PC communication link is made through the D-connector at the AS710 rear, and requires an RS232 interface unit and lead (supplied separately):-

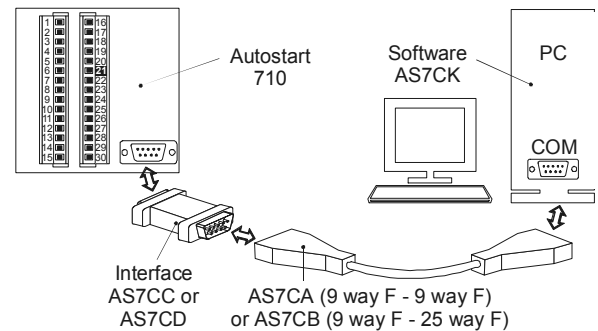

For detailed information about program functions and options, please refer to document mi5265. For information about communication links and PC software, please see document mi5266.

Electrical Connection

General

Electrical connection is through a pair of two-part type screw terminal blocks at the rear of the unit: the 2 connector blocks are labelled 1 - 15 and 16 - 30. Use a 3mm (1/8") flat head screwdriver to loosen and tighten each screw terminal. Before connection or disconnection, ensure that the unit is switched to O (off) and that all DC and AC power supplies are isolated.

WARNING: connection to or disconnection from live wiring can cause damage to internal components.

General wiring recommendations

Murphy make the following recommendations:-

Terminal blocks

- Ensure that no more than 2 wires are inserted into each screw terminal
- Ensure that terminal blocks are fully pushed home into Autostart rear fascia receptacles.

Battery chargers

Some battery chargers feature significant ripple and switching noise on the DC output. This electrical interference can be imposed on the panel power supply and control lines, with the potential to cause mal-operation of (and in extreme cases damage to) electronic control equipment.

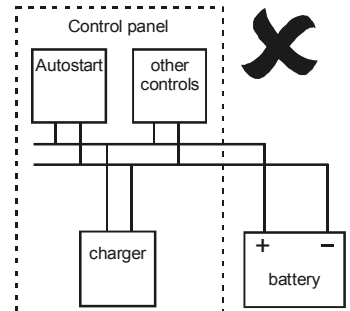

INSTALLATION INFORMATION (cont.)

Minimise the effects of charger output noise by using separate wiring 1) between charger output and battery terminals and 2) between battery terminals and panel DC supply rail.

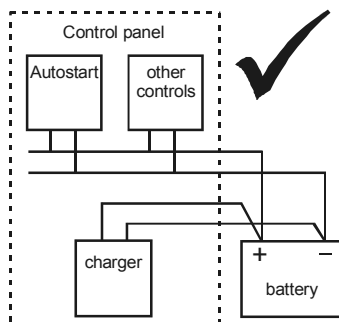

External Slave Relays are a recommended connection on all outputs (as shown right), either to achieve the required load switching capability, or to reduce wear and tear on internal relay contacts.

Slave relay and solenoid coils will naturally emit voltage spikes when de-energising. Suppress this interference at source using the relay manufacturer's recommended suppression network. DC coiled relays can also be suppressed using a reversed biased flywheel diode as shown right.

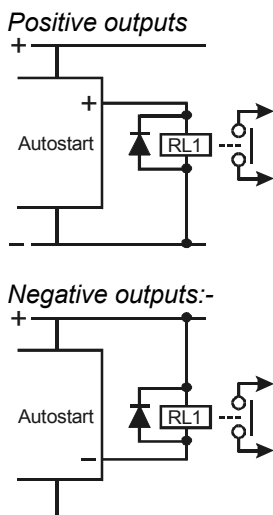

Terminal Functions

The functions of each connection are as follows:-

Terminal block 1 - 15

Pin	Function
1	Negative DC power supply
3	Positive DC power supply
2	Charge fail input
4	Positive DC (feed for relays)/Emergency stop
5	Magnetic pickup
6	Programmable output 1
7	Programmable output 2
9	Programmable output 3
10	Programmable output 4
8	A800 enable output
11	Remote start/mains fail input
12	No connection
13	Off/reset output
14	Manual mode output
15	Auto mode output

Autostart will operate with any clean, noise-free supply in the range 5 to 40 V DC (normally the engine's 12V or 24V battery). Connect a 5 Amp anti-surge fuse in the positive DC line (pin 3). See also 'general wiring recommendations' above regarding battery chargers.

In normal operation, Autostart measures its own DC supply voltage and displays this on the front facia. Autostart also provides warnings if the supply falls outside programmed under and over DC voltage limits.

A 'charge fail' warning may occur if pin 2 is switched to negative DC. The following program options are available:-

- a) Charge 'alternator'. Connect pin 2 to the charge alternator warning lamp (WL) terminal – note that Autostart provides the necessary charge excitation current. The 'WL crank cut' program settings allows the option of an automatic crank release above a pre-set charge alternator voltage.
- b) 'Mains charger'. Connect pin 2 to the 'charge fail' output of a Murphy BC700 series charger, or direct to negative DC via relay contacts which close on fault.

c) 'Not used' (or - -). Use this option if a charge fail alarm is not required, and leave pin 2 open circuit.

This positive DC connection provides a feed for the Fuel and Start outputs (pins 22 and 23). If required, emergency stop switches (push to break, mechanically latching types) may be wired between positive and pin 4: Autostart shuts down the engine and indicates 'emergency stop' if pin 4 is made open circuit.

Allows the optional use of a magnetic pickup (and engine flywheel) for sensing engine speed. Connect one pickup terminal to pin 5, the other terminal to pin 1 or battery negative. Use a two core and shield cable for inter-connection, with the shield grounded at one end only. Before use, the AS710 must be programmed with the correct number of flywheel teeth, and with correct trip levels (in engine RPM) for crank release, underspeed and overspeed.

These outputs may be programmed to give a range of signalling and control 'actions', e.g. 'preheat', 'engine running', 'overspeed', etc. Please refer to programming literature mi5265 for full details.

Electrically, all 4 terminals give a negative DC output when active. Outputs 1 to 3 are open collector transistor types, rated to a maximum current of 300mA. Output 4 is relay based, giving a switched negative output of up to 5 Amps.

The connection of slave relays is recommended, as detailed above in 'general wiring recommendations'.

Pin 8 may be used to give a 'seam free' operation with the Murphy A800 alarm/annunciator unit. The output may be connected directly to the A800 enable input: the A800 fault/warning inputs are only then enabled once the Autostart detects that the engine is running. No attempt should be made to connect pin 8 to anything other than an A800 enable circuit.

Use this input to initiate an automatic engine start in AUTO mode. Pin 11 must be switched to positive DC when the engine is required to be on standby, and made open circuit to initiate an automatic start.

Gives a negative DC output (250mA max.) when the key is switched to \bigcirc (off/reset).

Each of these terminals gives a positive DC output (250mA max) when Autostart is respectively switched to manual or auto modes.

INSTALLATION INFORMATION (cont.)

Terminal block 16 - 30

16 Input 1: (low) oil pressure (LOP)

17 Input 2: (high) engine temperature (HET)

Sender (analogue) inputs:-

On models AS710SKDA and AS710SKCA (and older variants AS710SKD and AS710SKC with V1.00 to V1.05 firmware), pins 16 and 17 may be used with one of several types of oil pressure and engine temperature resistive sender - see document mi5265 for details of the sender types permitted.

Two wire senders (not ground return senders) should be used for maximum accuracy. Connect one sender wire to the input; connect the second sender wire to battery negative, as close to Autostart pin 1 as possible.

When senders are used, Autostart displays engine temperature and oil pressure during normal operation, and permits the programming of separate levels for warnings (pre-alarms) and shutdowns.

Switch (digital) inputs:-

On models AS710SKDB and AS710SKCB, pins 16 and 17 are designed for use with low oil pressure and high engine temperature fault switches. The inputs may be programmed for use with either 'open on fault' or 'closed on fault' switches, with contacts wired between the input and battery positive or negative. In normal operation, an active input causes an immediate engine shutdown.

Switches or senders MUST be connected to ensure correct operation. Open circuit senders may result in 'sender fault' warning messages. Autostart also checks

the oil pressure input state before cranking: if a 'high oil pressure' input is measured, the AS710 does not crank the engine and displays 'BAD OIL PRESSURE'.

18 Input 3 (programmable)

19 Input 4 (programmable)

20 Input 5 (programmable)

These inputs may be used with switch contacts to trigger a range of programmable 'actions', e.g. shutdown fault, warning fault, lamp test, manual restore (of mains), etc. Full details of program 'actions' can be found in document mi5265.

Connect the switch contact between each input and battery positive or negative, and program each input to activate as required (open/closed/positive/negative).

21 Index pin (no connection)

22 Fuel output

23 Starter output

These are positive DC outputs, rated to 16 Amps, for the control of engine fuel and starter motor circuits. Connection of slave relays is recommended, as detailed above in 'general wiring recommendations'.

24 Programmable output 5

(default setting: 'common alarm')

Pin 24 is a positive DC relay output, rated to 5 Amps. With its default 'common alarm' setting, the output activates during any fault (warning or shutdown). The output can, however, be programmed to give other 'actions', as for inputs 1 to 4.

TYPICAL CONNECTION (AS710SK_A shown, mains fail generator application)

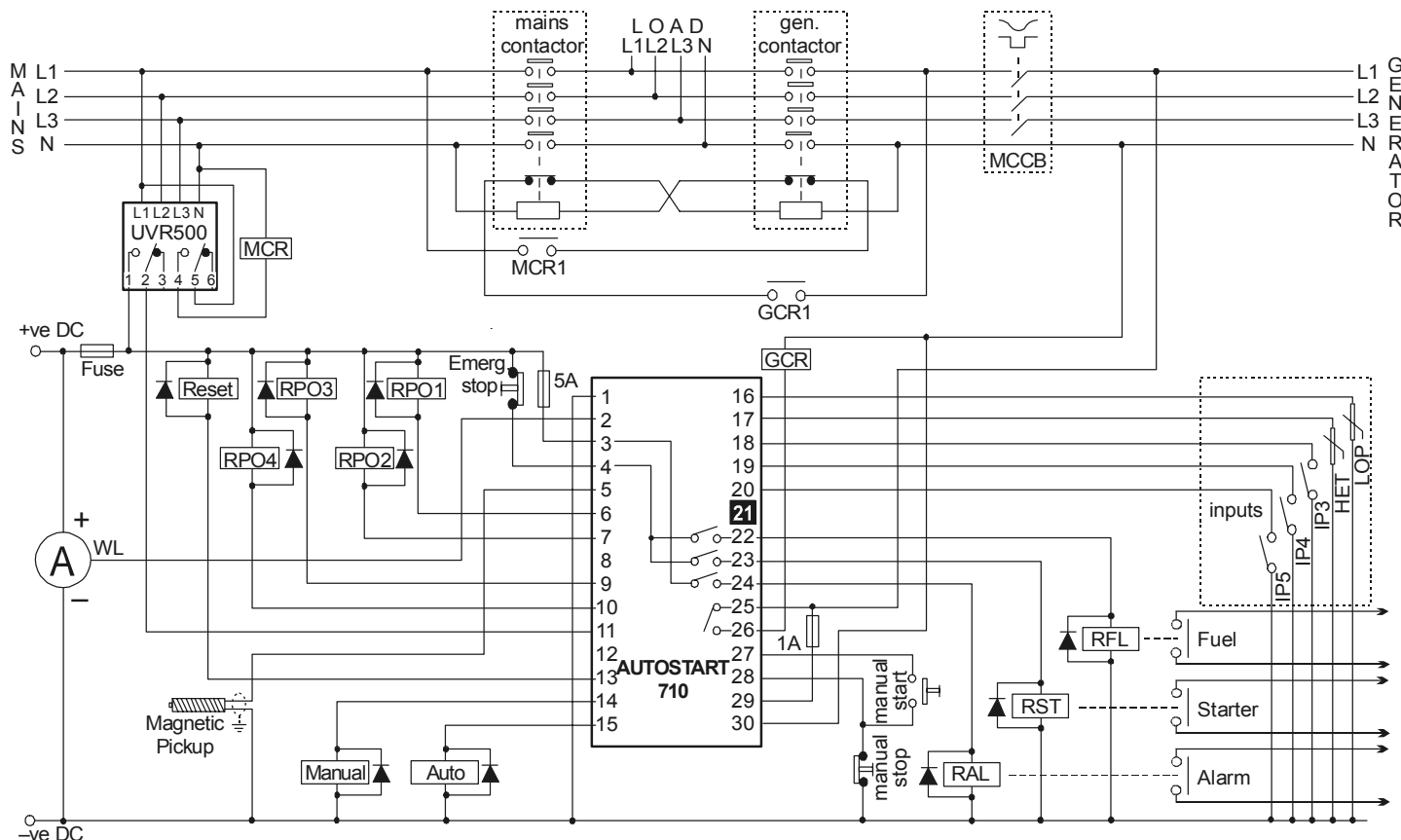

INSTALLATION INFORMATION (cont.)

25 Programmable output 6 (Normally Open contact)

26 Programmable output 6 (Change-over contact) (default setting: 'gen. contactor')

Output 6 is a volt-free set of normally open relay contacts, which can be programmed with the same range of 'actions' as outputs 1 to 5.

With its default 'gen. contactor' action, the output is typically used to control a generator contactor coil circuit. It will activate (contacts close) when:-

- a) generator voltage is above 66% of nominal (factory set, non-programmable)
- b) generator frequency/speed is above the programmed trip level
- c) oil pressure is OK, and
- d) after the 'warm-up' delay time has expired.



These terminals may be wired as above to panel push-buttons, allowing operator control of engine starting and stopping when the unit is switched to 'manual' mode. Alternatively, hard-wire pins 27 and 28 to battery negative to give an immediate engine start on switching to manual mode.

Note: pin 28 **must** be connected to battery negative during power up to ensure normal operation. If pin 28 is open circuit during power up, the AS710 adopts program mode.

29 Generator Live

30 Generator Neutral

For generator applications, connect these terminals to generator AC (50/60Hz). Line to neutral or line to line connections may be used, so long as the voltage does not exceed 300VAC. Connect a 1 Amp anti-surge fuse in series with the generator live terminal (pin 29).

Autostart uses these terminals to sense the generator voltage, and also its frequency when a magnetic pickup is not used. Correct voltage and frequency is needed to ensure the operation of a 'generator contactor' output; frequency alone may be used to trigger the automatic crank release and overspeed trip.

For non-generator applications (e.g. a diesel pump), leave these terminals open circuit and ensure that the 'AC sense' setting is programmed to 'no'. Speed sensing must then be made using a magnetic pickup (see pin 5).

Warranty and Maintenance

This unit is supplied with a 2 year warranty on parts and workmanship. Details are available on request and are supplied with each unit.

The AS705 contains no user-serviceable parts. Maintenance is therefore limited to the following preventative checks:-

- Check that the rear terminal blocks are pushed home fully, and that the wiring to screw terminals is secure.
- Check that the Autostart is securely clamped in the front of panel aperture, and kept free from ingress of water or build up of excessive dust/dirt. The front facia label and casing may be wiped with a clean, damp cloth. **Do not** use cleaning solvents.

The keys of all AS710 units are generally interchangeable, but note that the key type changed in Jan. 2001. The keys, fixing clamps, terminal blocks are available as spare components, as are the range of communication accessories:-

Stock code	Model ref	Description
76.70.0096	AS3/KEYB	1 pair of keys (L&F93201), for units Dec 2000 or earlier ('V' serial number or earlier)
76.70.0304	AS7/KEYC	1 pair of keys (L&F85000), for units Jan 2001 or later ('W' serial number or later)
76.70.0124	KEY/CLAMPS	1 pair of mounting clamps
76.70.0121	AS7TBA	Terminal block 1-15
76.70.0122	AS7TBB	Terminal block 16-30
76.70.0018	AS7CA	Comms lead (null modem), 9 way (interface) to 9 way (PC)
76.70.0019	AS7CB	Comms lead (null modem), 9 way (interface) to 25 way (PC)
76.70.0020	AS7CC	Interface, Autostart to RS232 local communication
76.70.0021	AS7CD	Interface, Autostart to RS232 modem communication
76.70.0203	AS7CK	PC software for AS7xx communication and programming (<i>also available free of charge from the 'Downloads' section of www.fwmurphy.co.uk</i>)

In the event of a fault or technical query, please contact your Murphy representative for technical support. Technical documents are also available from the Products sections of our website www.fwmurphy.co.uk.



FW Murphy
PO Box 470248
Tulsa, Oklahoma 74147, USA
tel: +1 918 317 4100
fax: +1 918 317 4266
email: sales@fwmurphy.com
web: www.fwmurphy.com

CONTROL SYSTEMS AND SERVICES DIVISION
PO Box 1819, Rosenberg, Texas 77471, USA
tel: +1 281 633 4500
fax: +1 281 633 4588
email: sales@fwmurphy.com

MURPHY DE MEXICO S.A. DE C.V.
Blvd. Antonio Rocha Cordero 300, Fracción del Aguaje
San Luis Potosí, S.L.P. México 78384
tel: +52 444 8206264
fax: +52 444 8206336
Villahermosa office tel: +52 993 3162117
email: ventasamex@murphymex.com.mx
web: www.murphymex.com.mx

FRANK W. MURPHY LTD.
Church Rd, Laverstock, Salisbury, SP1 1QZ, UK
tel: +44 1722 410055
fax: +44 1722 410088
email: sales@fwmurphy.co.uk
web: www.fwmurphy.co.uk

MURPHY SWITCH OF CALIFORNIA
41343 12th Street West,
Palmdale, CA 93551-1442, USA
tel: +1 661 272 4700
fax: +1 661 947 7570
email: sales@murphyswitch.com
web: www.murphyswitch.com

MACQUARRIE CORPORATION
1620 Hume Highway,
Campbellfield, Victoria 3061, Australia
tel: +61 3 9358 5555
fax: +61 3 9358 5558
email: murphy@macquarrie.com.au



USA - ISO9001:2000 FM 28221
UK - ISO9001:2000 FM 29422

In order to consistently bring you the highest quality, full featured products, we reserve the right to change our specifications and designs at any time.