

Fire Shutoff Valve



FSV Series

- Effective Spring-Loaded, Snap-Acting Oil Supply Shutoff Mechanism
- Steel-to-Steel Seat
- Carbon Steel Construction With Key Components of Stainless Steel
- Low Maintenance-Low Cost, the Direct Replacement for More Expensive Valves
- Ideal for Use With Murphy's LM300 and LM2000 Oil Level Maintainers
- For 1/2 or 3/4 NPT Inlet/Outlets

Description

The Murphy FSV Series, Fire Shutoff Valves are spring-loaded, snap-acting, shutoff valves for use with automatic lube level maintainers. In case of fire, the FSV valves will automatically shut off the oil flow from the engine and the oil supply reservoir for the oil level maintainer. This will prevent adding oil to the fire. Murphy's FSV Series Fire Shutoff Valves are rugged, built-to-last devices and are available with 1/2 NPTF or 3/4 NPTF inlet and outlet.

Basic Operation

During a fire the Oil Level Maintainer/controller could be damaged, allowing oil to flow without restriction from the supply reservoir or in reverse direction from the crankcase to the fire. The FSV Fire Shutoff Valve will prevent the oil from adding to the fire. Once the ambient temperature rises above the FSV high temperature setting, its built-in fusible element melts, activating the valve oil flow shutoff mechanism. To achieve this task, two FSV Fire Shutoff Valves are needed.

Applications

The FSV Series valve can be used on any supply line where there is a need for valve closure due to excessive heat such as fire. The primary market for this product is engine and engine-driven equipment. Applications include engine oil, compressor oil, and lubricator oil systems. A typical engine-driven compressor skid has the potential for six fire shutoff valves, with four being very common.

Specifications

Valve Body: Carbon steel (Zinc plated).

Valve Plunger: Carbon steel (plated).

Spring: Stainless steel.

Working Pressure: 75 psi (517 kPa) [5 bar].

Fusible Element Melting point:

360°F (182°C) ±2% (other ranges available—contact FWMurphy for details).

Elastomer Parts: Viton®, compatible with engine oil. Maximum temperature 400°F (204°C) under normal operating conditions.

Connection Sizes: 1/2 and 3/4 NPTF inlet/outlet.

Dimensions

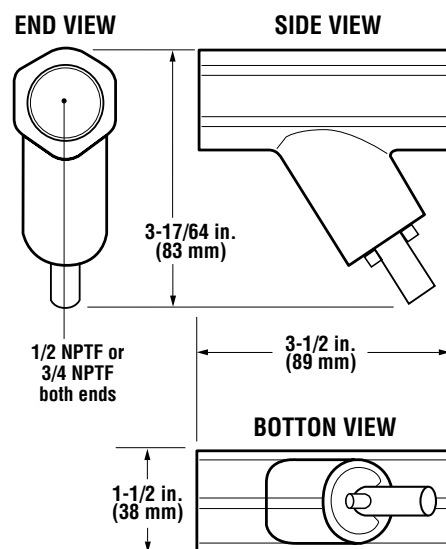

Warranty

A two-year limited warranty on materials and workmanship is given with this Murphy product. Details are available on request and are packed with each unit.

FSV Series Typical Installation



WARNING: Perform this installation using appropriate protection. Trapped air and hot oil may cause burns.

IMPORTANT: The recommended installation for the Murphy FSV Series Fire Shutoff Valve is with the stem facing down. (See Figure below.) It is recommended to use metallic tubing or pipe in these installations, as opposed to rubber hose.

Inlet Side

Install an FSV Series Fire Shutoff Valve as close as possible to the Murphy LM2000 or LM300 Series Oil Level Maintainer (See figure below). In case of fire, the FSV Valve will stop oil flow from the oil supply tank.

Outlet Side

Install a second FSV Series Fire Shutoff Valve as close as possible to the engine crankcase. (See figure below.) In case of fire, the FSV Series valve will stop backflow from the engine crankcase.

Typical Installation Diagram Shown with Murphy's LM2000 Oil Level Maintainer

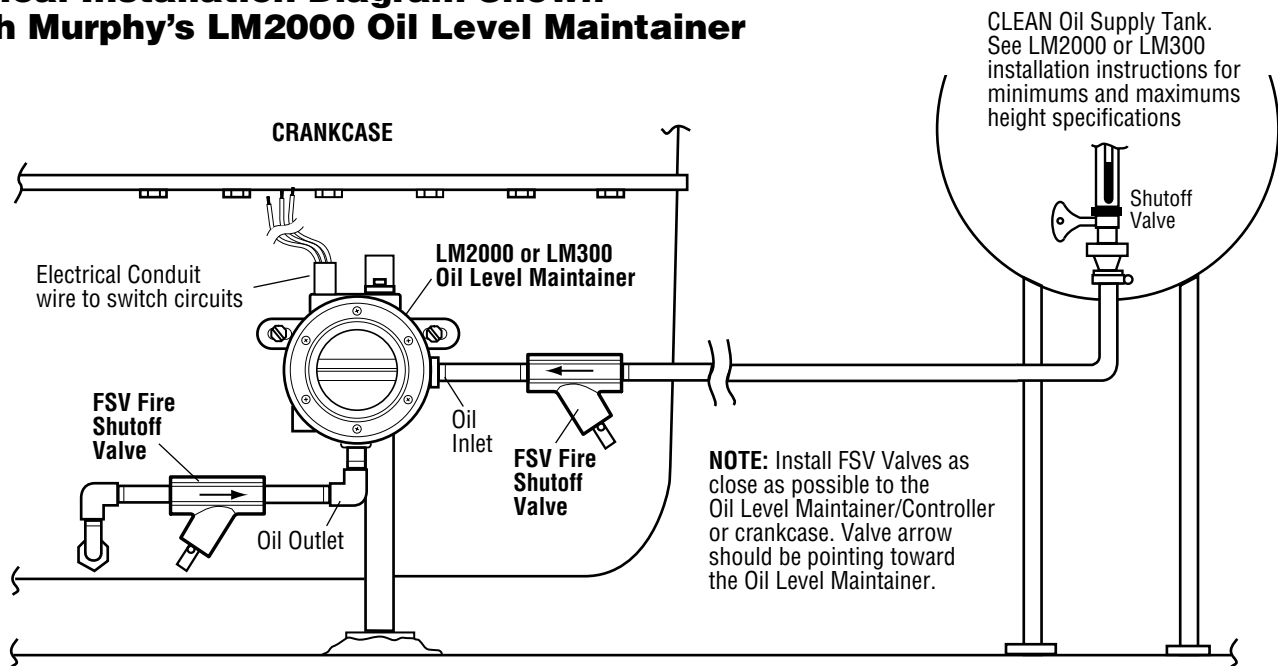

How to Order

To order your FSV Fire Shutoff Valve, please specify the model number:

FSV-50-360 (55700297): 1/2 NPTF inlet/outlet Fire Shutoff Valve.

FSV-75-360 (55700296): 3/4 NPTF inlet/outlet Fire Shutoff valve.

55000228: FSV Repair kit (includes: stem, seals, spring and snap ring).

murphy

FWMurphy

P.O. Box 470248

Tulsa, Oklahoma 74147 USA

(918) 627-3550

fax (918) 664-6146

e-mail sales@fwmurphy.com

www.fwmurphy.com



Printed in U.S.A.

CONTROL SYSTEMS & SERVICES DIVISION

P.O. Box 1819; Rosenberg, Texas 77471; USA

(281) 342-0297 fax (281) 341-6006

e-mail sales@fwmurphy.com

MURPHY DE MEXICO, S.A. DE C.V.

Bldv. Antonio Rocha Cordero 300, Fracción del Aguaje

San Luis Potosí, S.L.P.; México 78384

+52-48-206264 fax +52-48-206336

e-mail ventasmex@murphymex.com.mx

FRANK W. MURPHY, LTD.

Church Rd.; Laverstock, Salisbury SP1 1QZ; U.K.

+44 1722 410055 fax +44 1722 410088

e-mail sales@fwmurphy.co.uk

www.fwmurphy.co.uk

For Service in French:

Pour service en français:

+44 1722 410697 fax +44 1722 410088

e-mail france@fwmurphy.co.uk

www.fwmurphy.co.uk/francais.htm

MURPHY SWITCH OF CALIFORNIA

41343 12th Street West

Palmdale, California 93551-1442; USA

(661) 272-4700 fax (661) 947-7570

e-mail sales@murphyswitch.com

www.murphyswitch.com

MACQUARRIE CORPORATION

1620 Hume Highway;

Campbellfield, Vic 3061; Australia

+61 3 9358-5555 fax +61 3 9358-5558

e-mail murphy@macquarrie.com.au

In order to consistently bring you the highest quality, full featured products, we reserve the right to change our specifications and designs at any time.