

# Automatic Engine Controller



## Model ASM160

- Ideal for Generator or Pumping Applications
- Selectable Glowplug or Warmup/Cooldown Mode
- Built-In Crank Disconnect and Overspeed Function
- Advanced, Rugged, Reliable Microprocessor-Based Design
- Compatible with Mechanical or Electrical Murphy SWICHGAGE® Instruments
- Four First-out Shut-down LED's

### Description

The ASM160 is an engine controller with automatic start and stop, and selectable warmup/cooldown or glowplug capabilities.

The ASM160 operates from 12 or 24 volt battery. It includes features such as selectable crank and rest cycles, sensing circuit for crank disconnect and overspeed, overcrank, and re-crank protection on false starts. Four LED's indicate first-out shutdown for: low oil pressure, high temperature, overcrank and overspeed. There is a fifth LED for engine running. There are also two (2) spare inputs that will cause the unit to shut down without annunciation on the front LED's.

Advanced microprocessor circuitry gives the ASM160 high reliability and flexibility.

The ASM160 is compact and housed in a durable metal case. It mounts flush in a panel and requires very little room. Due to its low cost and many features, the ASM160 is ideal for small generator and engine panels and for pumping applications.

### Features

- Compact Design Is Easy-to-Install
- Optically Isolated Noise Resistant Inputs
- Loss of Speed Signal Shutdown
- Selectable Engine Cranking Attempts for 3, 5, 10 or Infinite Attempts.
- 15 Second, Start-up Lockout Time Delay
- Adjustable Dual Function Speed Sensing
- Relay Outputs for Cranking and Fuel Valve
- Outputs for Fault Annunciation
- Output for Glowplug or Warmup/Cooldown Functions

### Specifications

**Power Input:** 12 or 24 VDC.

**Operating Temperature:**  
-40 to 185°F (-40 to 85°C).

**Ground or Positive Inputs for:** High temperature, low pressure, and two spares.

**Lamp and Output Test:** One ground-only input for lamp and output test.

**Outputs:** 5 A relay for cranking and fuel valve. 300 mA transistor for fault annunciation, glowplug, or warmup/cooldown.

**Cycle Crank Timer:** Selectable to 3, 5, 10 or infinite attempts.

**Crank/Rest Cycle Timing:**  
Crank time 10 sec.; rest time 15 seconds.

**Glow Plug Time Delay:** Field adjustable from 1 to 300 seconds.

**Warmup Time Delay:** Field adjustable from 1 to 300 seconds.

**Cooldown Time Delay:** Field adjustable from 1 to 300 seconds.

**Shutdown Lockout Time Delay:** 15 second lockout for low oil, high temperature, one spare, loss of speed shutdown on start-up.

**Crank Disconnect Speed Setting:**  
Field adjustable from 30 to 8500 Hz.

**Overspeed Trip Point Setting:**  
Field adjustable from 30 to 8500 Hz.

**Magnetic Pickup Input:**  
Requires 3V rms minimum 30 to 100 Hz;  
Requires 2V rms minimum 100 Hz and up;  
Maximum 35V rms.

**Shipping Weight:** 2 lb. (1 kg.).

**Shipping Dimensions:** 6-1/4 x 6-1/4 x 4-1/2 in. (159 x 159 x 114 mm).

## Dimensions

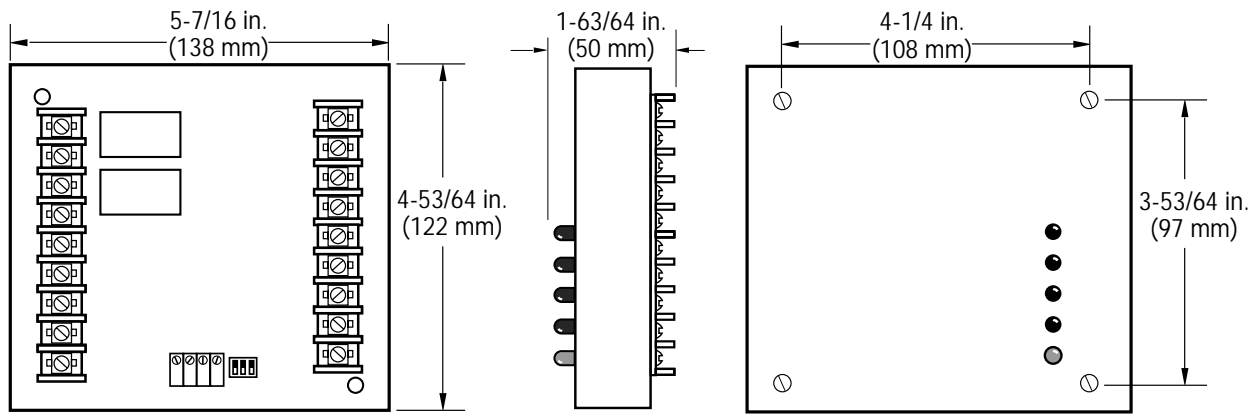

## Typical Wiring Diagram

NOTES: 1 Close to start and run, open to stop.

2 For Pilot Duty Only. External Load not to exceed 5 A. Place reverse bias diodes across induction loads.

3 Remote lights (if used) not to exceed 300 mA.

4 At Load/Glow Plug Relay not to exceed 300 mA.

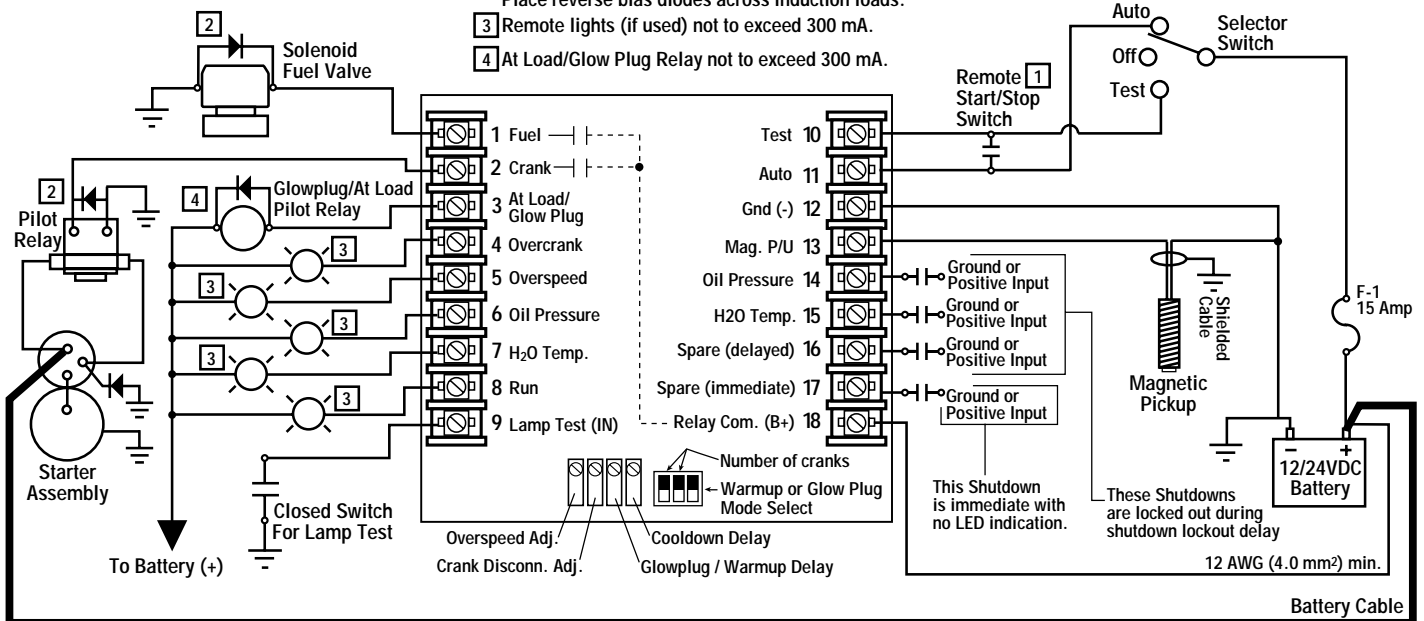

## How to Order

Specify ASM160

## Warranty

A two-year limited warranty on materials and workmanship is given with this Murphy product. Details are available on request and are packed with each unit.

Find us on the internet:

<http://www.fwmurphy.com>

*In order to consistently bring you the highest quality, full featured products, we reserve the right to change our specifications and designs at any time.*



■ **Frank W. Murphy Manufacturer**  
P.O. Box 470248; Tulsa, Oklahoma 74147; USA  
tel. (918) 627-3550 fax (918) 664-6146  
e-mail fwmurphy@ionet.net

■ **Frank W. Murphy Southern Division**  
P.O. Box 1819; Rosenberg, Texas 77471; USA  
tel. (281) 342-0297 fax (281) 341-6006  
e-mail murphysd@intertex.net

■ **Frank W. Murphy, Ltd.**  
Church Rd.; Laverstock, Salisbury SP1 1QZ; U.K.  
tel. +44 1722 410055 fax +44 1722 410088 tlx 477088  
e-mail sales@fwmurphy.co.uk

■ **Frank W. Murphy Pte., Ltd.**  
26 Siglap Drive; Republic of Singapore 456153  
tel. +65 241-3166 fax +65 241-8382  
e-mail fwmurphy@fwmurphy.com.sg

■ **Murphok Pty., Ltd.**  
1620 Hume Highway; Campbellfield, Vic 3061; Australia  
tel. +61 3 9358-5555 fax +61 3 9358-5558

■ **Murphy de México, S.A. de C.V.**  
Blvd. Antonio Rocha Cordero 300, Fracción del Aguaje  
San Luis Potosí, S.L.P.; México 78384  
tel. +52-48-206264 fax +52-48-206336  
e-mail murmexsl@infosel.net.mx

■ **Murphy Switch of California**  
P.O. Box 900788; Palmdale, California 93590; USA  
tel. (805) 272-4700 fax (805) 947-7570  
e-mail sales@murphyswitch.com

■ **Frank W. Murphy France**  
tel. +33 1 30 762626 fax +33 1 30 763989