



HelmView™ Accessory Kit

Installation Guide

In order to consistently bring you the highest quality, full featured products, we reserve the right to change our specifications and designs at any time. The latest version of this manual can be found at www.fwmurphy.com.

Warranty - A limited warranty on materials and workmanship is given with this FW Murphy product. A copy of the warranty may be viewed or printed by going to www.fwmurphy.com/support/warranty.htm



Please read the following information before installing.

**BEFORE BEGINNING INSTALLATION OF THIS MURPHY
PRODUCT:**

- Read and follow all installation instructions.
- Please contact FW MURPHY immediately if you have any questions.

Table of Contents

HelmView Accessory Kit Structure.....	1
HelmView Mounting Kit	1
GPS Kit	2
NMEA Backbone Kit.....	2
Multisensor Kit.....	3
Gimbal Mount.....	3
Remote Keypad	4
Mounting Instructions	6
Installing an NMEA 2000® Network.....	7
Cable and Connector Network Basics.....	7
Installing Terminators	8
Supplying Power	8
Ground the Network	9
Checking Your Network	9

(THIS PAGE INTENTIONALLY LEFT BLANK)

HelmView Accessory Kit Structure

The following accessory kits are available for the HelmView Model HV1000:

- HelmView Mounting Kit (PN 78-70-0232)
- GPS Kit (PN 78-70-0261)
- NMEA Backbone Kit (PN 78-70-0266)
- Multisensor Kit (PN 78-70-0267)
- EVC Kit (PN 78-70-0366)
- Gimbal Mount (PN 78-70-0260)

HelmView Mounting Kit

Kit includes mounting hardware and plastic drilling/cutout template. Map card is included with optional GPS Kit.

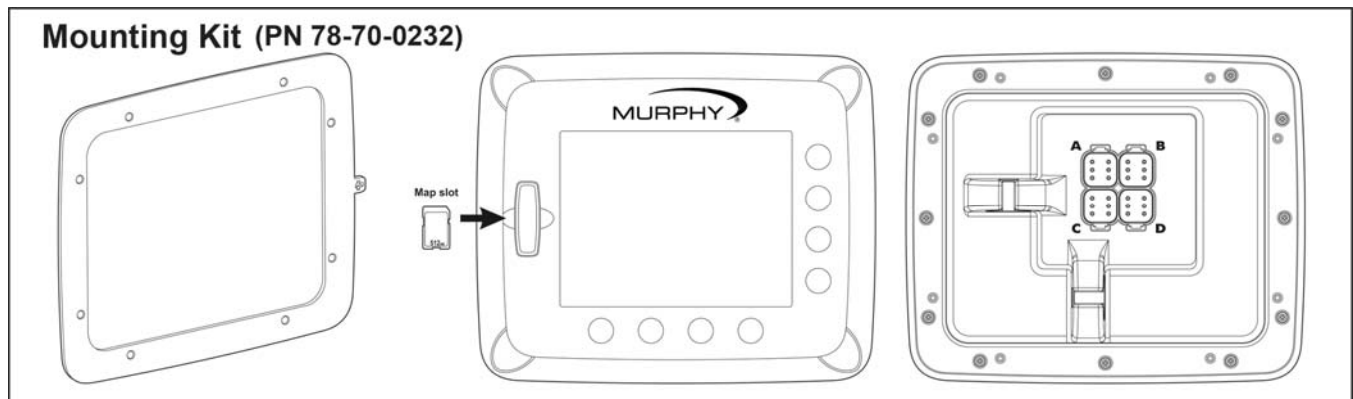

NOTE: Plastic template should be used to help determine clearance around mounting area. Once clearance has been verified, use template to drill and cut holes for display mounting.

GPS Kit

This kit includes a Map card and connections.

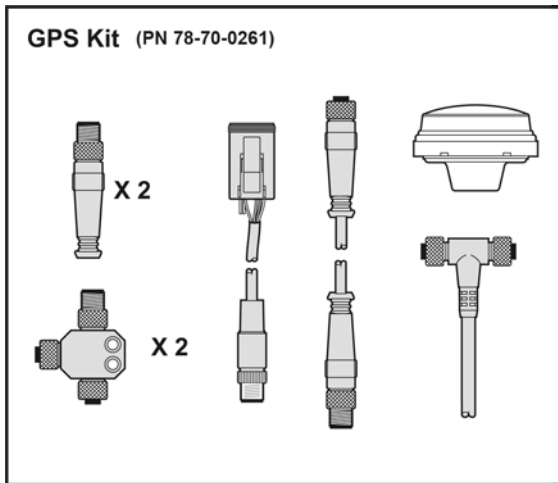

NOTE: Optional detailed area upgrades for map cards may be purchased at any Navionics dealer.

NMEA Backbone Kit

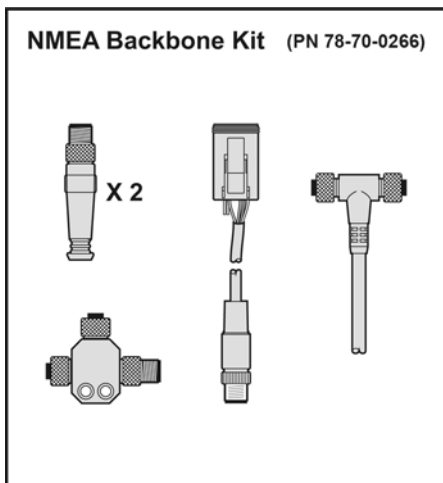

Multisensor Kit

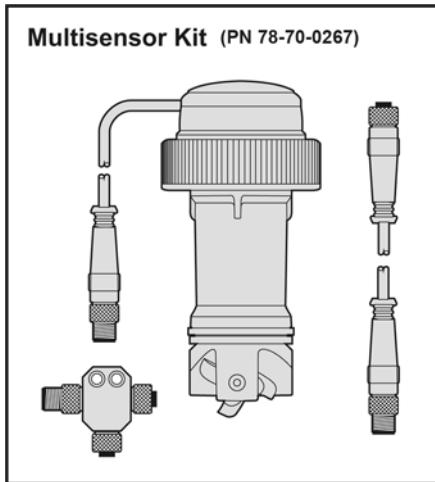

Gimbal Mount

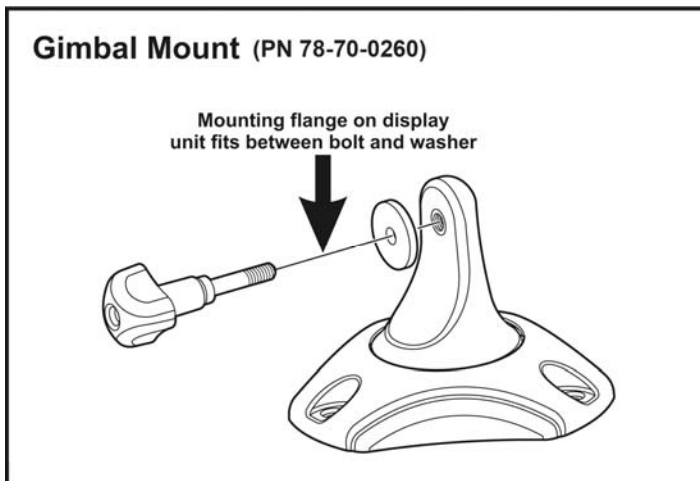

NOTE: Mounting method and hardware used depend on mounting surface. May be mounted using lag bolts or, if surface is not thick enough, using nuts and bolts.

Also, a “pass-through” hole will need to be cut out for all cables running up to the display. Hole should be located behind the gimbal mount to partially hide any cables.

Remote Keypad

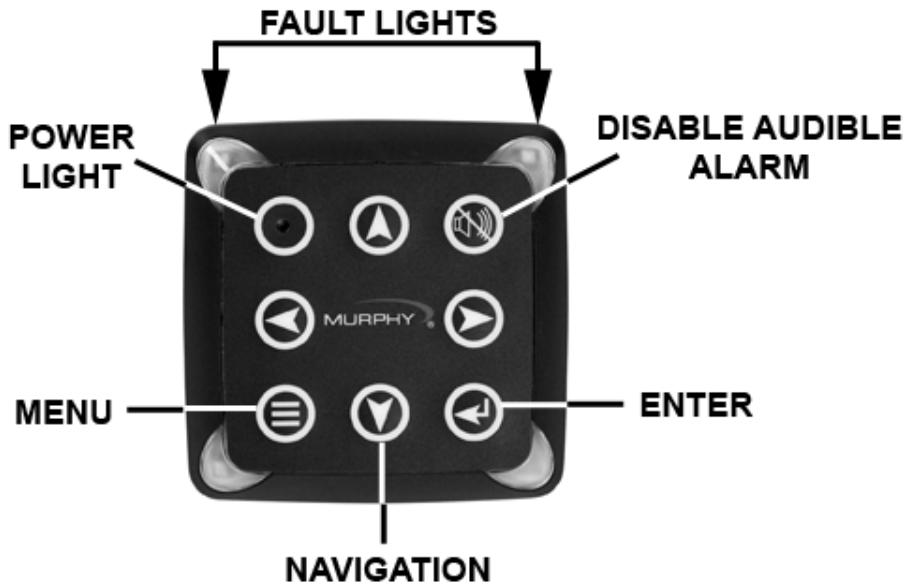

The **Remote Keypad** works with Murphy's PV1000 and HV1000 model displays. It allows a user to enter keypad commands whenever display installations are not conveniently located for easy access.

The keypad contains the same navigation, menu and selection keys as found on the displays, making it an easy transition to use. Fault lights, just like the ones found on the displays, are located in the corners of the keypad. An audible alarm with a one-touch key for temporarily disabling is provided, making it easy to recognize and address faults and alarms.

Specifications

I. Electrical

Processor: PIC18F2510
Flash Memory: 32 Kbytes
RAM: 1536 bytes SRAM
Backlighting: LED, 7400 mcd
Operating Voltage: 6 to 32 VDC, protected against reverse polarity and load-dump
Power Consumption: 3.2 W maximum
Connection: 2 Deutsch DT 6-pin connectors
Keyboard: 7 Membrane Switch Keys
Audible Alarm: 70dB minimum

I. Environmental

Operating Temperature: -40 to 70°C (-40° to 158°F)
Storage Temperature: -55 to 85°C (-67° to 185°F)
Emissions: SAE J1113, IEC 60945, EN 12895, EN 61000

I. Mechanical

Mounting Type: Screw-on clamp
Dimensions (W x H):

- 3.88 x 3.88 inch (Landscape)
- Panel Mount Depth – 0.5922 inch
- Unit Depth – 2.173 inch

Cutout for Panel Mounting (Diameter): 2.062 inch
Case Material: Polycarbonate
Weight: 0.4 lb (180 g)

Product Dimensions

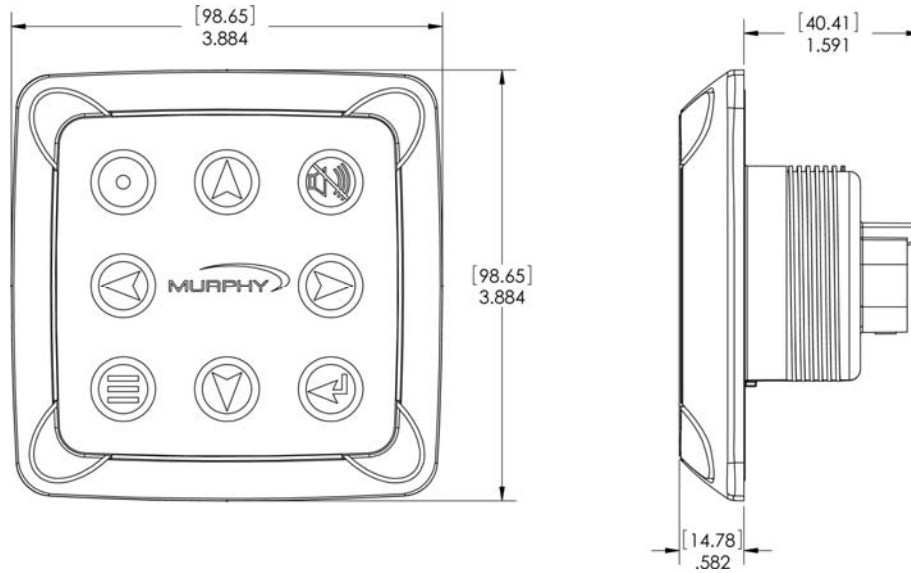

Electrical Connection

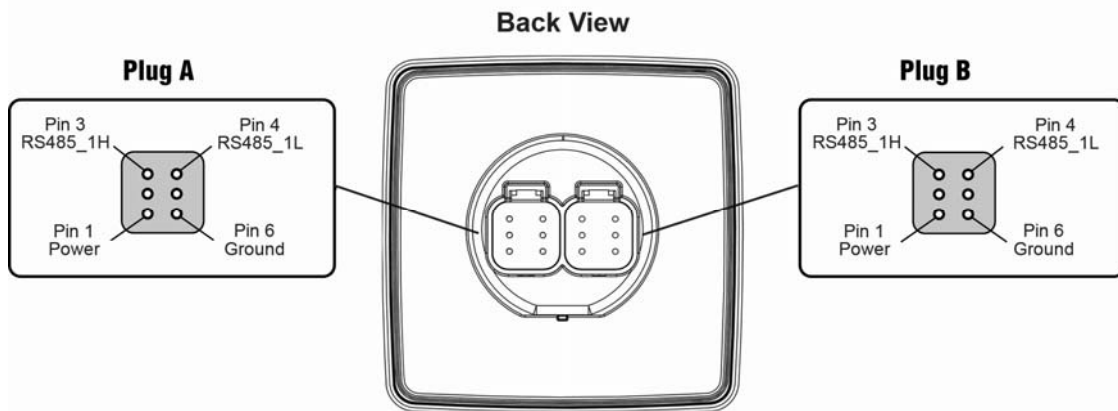

Mounting Instructions

Mounting options are shown below.

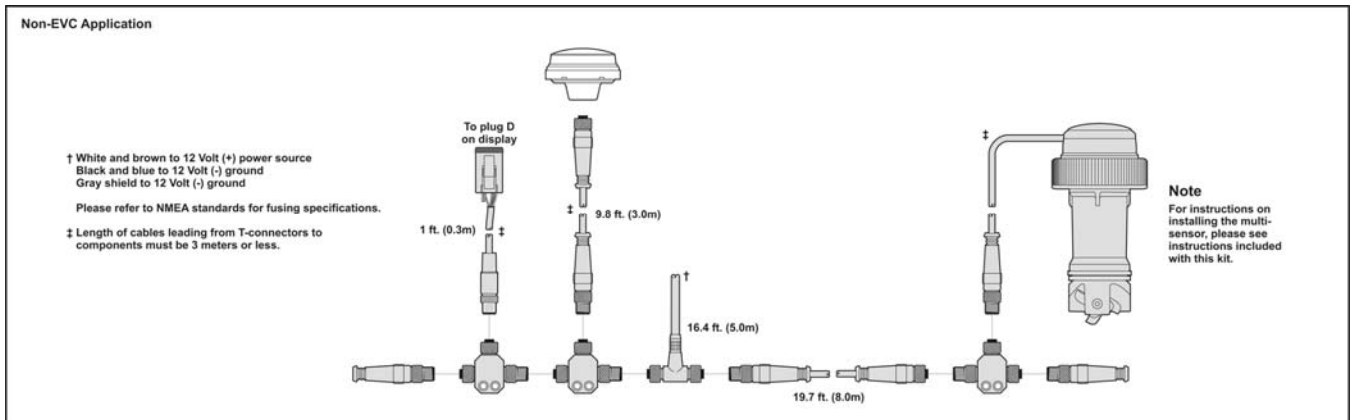

Mounting option 1: On a mounting flange and 1-inch pipe (not included in kit) using provided flange, screws and washers.

NOTE: Must be located as close as possible to the center of gravity of the boat.

Mounting option 2: Surface mount using screws (8-32) of suitable length.

NOTE: For guidelines on NMEA cabling, drop lengths, and other network basics, refer to the “Installing an NMEA 2000® Network” section of this guide.

Installing an NMEA 2000® Network

Installing an NMEA 2000 consists of interconnecting NMEA 2000 electronic devices using plug-and-play cables and connectors. The following pages provide a brief description of how to setup a NMEA 2000 network using five basic steps:

1. Cable and Connector Network Basics
2. Installing Terminators
3. Supplying Power
4. Grounding the Network
5. Checking the Network

Please note that this installation guide contains a brief description of the basic concepts of installing an NMEA 2000 network. You can learn more about installing NMEA 2000 networks by contacting the National Marine Electronics Association (NMEA) at www.nmea.org and consulting the following documents:

- NMEA 2000 Standard for Serial-Data Networking of Marine Electronic Devices
- NMEA Installation Standards

Cable and Connector Network Basics

Network Topology

The NMEA 2000 cable system uses a trunk (sometimes referred to as the backbone), drop line, drop tee, and termination resistor.

The NMEA 2000 cable system includes five wires within a single waterproof cable: two signal wires, power and ground wires, and a drain wire. The drain wire shields the signal, power, and ground wires from external Radio Frequency Interference (RFI) and helps reduce RFI emission from the cable.

Maximum Cable Distance

The cable distance between any two points in the cable system must not exceed 100 meters (328 feet) for the Micro cable.

Maximum Drop Line Length

The maximum cable distance from any device on a branching drop line to the trunk link is 6 meters (20 feet).

Maximum Number of Devices

A maximum of 50 physical devices shall be connected to the network, and the disconnection of any device shall not interrupt any other device on the network.

NMEA 2000 Cable

Micro cables contain five wires: One twisted pair (red and black) for 12VDC power, one twisted pair (blue and white) for signal and a drain wire (bare).

Installing Terminators

Termination resistors are attached to each end of the trunk cable to reduce reflections of the communication signals on the network. If you do not use termination resistors as described, the network will not operate properly. Termination resistors are typically connected directly to the last tee on the trunk line although they can be connected to a cordset extending from the last tee on a trunk line.

Supplying Power

NMEA 2000 networks can use a power supply originating from a single-point connection to the vessel's 12 volt battery or one or more isolated power supplies distributed along the network, but not a combination of battery and power supply connections. Over current protection should be provided and should be sized in accordance with ABYC E-11, AC and DC ELECTRICAL SYSTEMS ON BOATS, taking into consideration the smallest gauge of cable being used for the backbone or drop cables. The NET-S wire is connected to the positive side of the battery while NET-C is connected to the negative side of the battery.

Micro Power Capability

Micro cable is rated to 4 amps, however strategic placement of the power source could support higher current. For example, 8 amps of power could be supplied to the middle of the trunk where 4 amps is supplied to both sides of the power tap. It can handle large loads as long as no more than 4 amps is drawn through any single segment of the trunk line. However, cable resistance may limit your application to less than 4 amps.

Maximum Power Supply Voltage Drop

The NMEA 2000 network is designed to work properly as long as there is no more than a 1.5 volt difference in the power supply voltage between any two devices on the network. Therefore, you should perform an estimate of the voltage drop across a network using the following equation:

$$\text{Voltage Drop} = 0.1 \times \text{Network Loads} \times \text{Network Length} \times \text{Cable Resistance} / 100$$

Where: Network Loads is sum of Load Equivalent Numbers (LEN) for all devices

Network Length is in meters

Cable resistance is in ohms/100 meters

Ground the Network

The NMEA 2000 network should be grounded at ONE location. Grounding at more than one location may produce ground loops, which can cause problems with communications on the network. In addition to the ground wire, connect the drain or SHIELD wire at the supply ground location and NO other place.

Checking Your Network

Verify that the network has been correctly designed and installed by reviewing the following checklist:

- Number of devices does not exceed 50
- Maximum Micro cable distance between any two devices does not exceed 100 meters (328 feet)
- No drop should be greater than 6 meters (20 feet)
- Termination resistors are installed on both ends of the trunk
- The network is grounded at a single location
- The SHIELD wire is connected to a single point, the supply ground

MURPHY, the Murphy logo, HelmView™ and HV1000™ are registered and/or common law trademarks of Murphy Industries, Inc. This document, including textual matter and illustrations, is copyright protected by Murphy Industries, Inc., with all rights reserved. (c) 2007 Murphy Industries, Inc. Other third party product or trade names referenced herein are the property of their respective owners and are used for identification purposes only.

FW MURPHY

P.O. Box 470248
Tulsa, Oklahoma 74147 USA
+1 918 317 4100 Fax: +1 918 317 4266
E-mail: sales@fwmurphy.com

INDUSTRIAL PANEL DIVISION

Fax: +1 918 317 4124
E-mail: ipdsales@fwmurphy.com

MURPHY POWER IGNITION

Web site: www.murphy-pi.com

www.fwmurphy.com

CONTROL SYSTEMS & SERVICES DIVISION

P.O. Box 1819
Rosenberg, Texas 77471 USA
Phone: +1 281 633 4500 Fax: +1 281 633 4588
E-mail: sales@fwmurphy.com

FRANK W. MURPHY, LTD

Church Rd Laverstock
Salisbury SP1 1QZ UK
Phone: +44 172 241 0055 Fax: +44 172 241 0088
E-mail: sales@fwmurphy.co.uk
Web site: www.fwmurphy.co.uk

COMPUTRONIC CONTROLS, LTD

41 - 43 Railway Terrace Nechells
Birmingham B7 5NG UK
Phone: +44 121 327 8500 Fax: +44 121 327 8501
E-mail: info@computroniccontrols.com
Web site: www.computroniccontrols.com

FW MURPHY INSTRUMENTS (HANGZHOU) CO. LTD

77 23rd Street
Hangzhou Economic & Technological Development Area
Hangzhou, Zhejiang 310018 China
Phone: +86 571 8788 6060 Fax: +86 571 8684 8878



Printed in U.S.A.