

Swichgage® Shutdown Panel Kit

Models W0168 and W0241

The W0168 and W0241 panel kits are universal-fit instrument panels for most industrial engines. They include Swichgage protection for low engine oil pressure and high coolant or high oil temperature. These Panel Kits are similar – the W0168 has a start/stop key switch and the W0241 has a start push button.

The Swichgage product is two instruments in one: (1) an accurate indicating gage with (2) a built-in, adjustable limit switch.

A 518PH Magnetic Switch provides a closed-loop circuit to ensure proper operation at all times. The 518PH allows the system to be sensitive to open circuits, broken wires, false grounds, corrosion, loss of power and other factors which could otherwise prevent the protective controls from operating.

The universal mounting panel is enclosed on all four sides with an open back. An optional back cover is available for both kits. Panel Kits are pre-wired and ready to install and are available for 12- or 24-VDC systems.



W0168

Features

- Low Lube Oil Pressure Swichgage instrument
- High Coolant/Oil Temperature Swichgage
- 518PH Magnetic Switch
- Emergency stop push button
- Ignition key switch for start/stop (W0168)
- Push button for start (W0241)
- Ammeter 60-0-60
- Provisions for additional Swichgage controls, such as irrigation pump pressure or engine oil temperature
- Provisions for tachometer and throttle cable

Specifications

Low Lube Oil Pressure Swichgage Instrument:

0-100 psi (0-689 kPa) [0-6.89 bar]
1/8 NPT process connection

High Coolant/Oil Temperature Swichgage Instrument:

130°-250°F (54°-121°C)
48 in. (1.2 m) capillary
1/2 NPT process connection

518PH Magnetic Switch: 12 or 24 volt (specify)

Ammeter: 60-0-60

Shipping Weight: 8 lbs. 8 oz. (3.9 kg.)

Shipping Dimensions: 16 x 11 x 5-1/2 in. (406 x 279 x 140 mm)

Dimensions

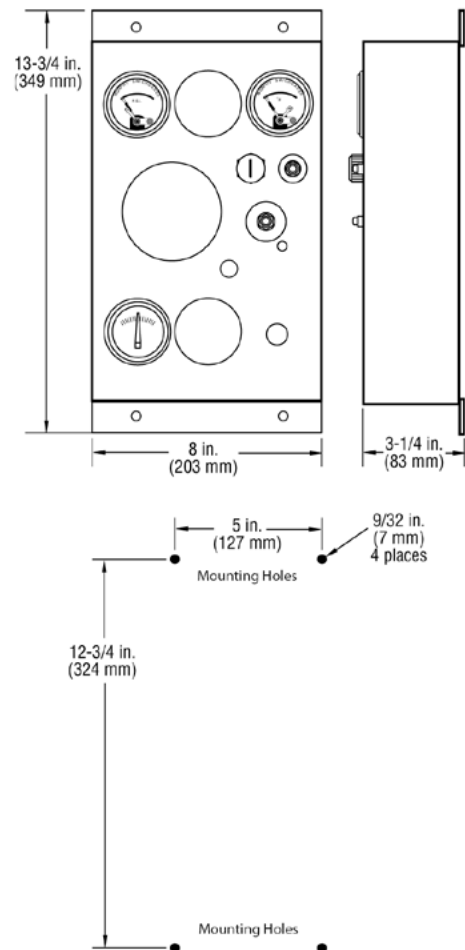

Typical Wiring Diagram

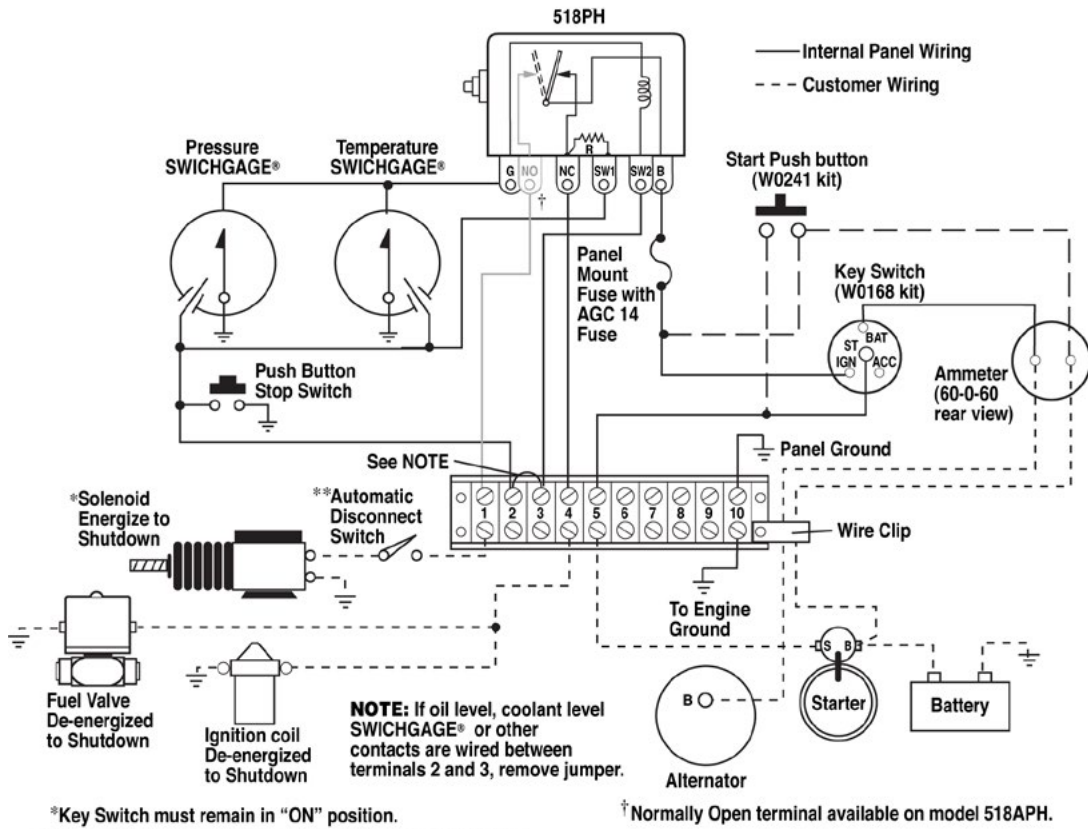

Always provide proper circuit protection with fuses or circuit breakers.

How to Order

Part Number	Model and Description	Notes
Specify Model Number	W0168: Panel Kit, start/stop key switch	12-volt kit is standard. If you require 24-volt kit - specify when ordering
	W0168B: Panel Kit with back cover, start/stop key switch	
	W0241: Panel Kit, start push button	