

MVP-R

Proportional Valve Ramping Controller User Manual



www.hctcontrols.com

Revision Record

Rev	Description	Date Released	Last Updated by
Rev A	Initial Revision	16-Dec-13	WB
Rev B	Upgrade to 32V and IP65 ratings	14-Oct-14	WB

Contents

Revision Record.....	2
HCT Introduction.....	4
Product Use Limitations.....	4
Product Application Guidelines.....	5
MVP-R Ramping Controller.....	6
Operating Specifications.....	6
Physical Description.....	7
User Interface.....	7
Configuration.....	8
Parameter List.....	11
Wiring.....	13
Order Information.....	13
Application Examples.....	14
Single Solenoid Control.....	14

HCT Introduction

Welcome to **High Country Tek** Inc. HCT is North America's foremost independent designer and producer of modular, ruggedized digital and analog electronic controllers for the fluid power industry.

From our factory in California, we manufacture 'specialty' controllers for specific functions and the user programmable 'DVC family' to enable large area networked system solutions.

The modules are used in mobile, industrial and marine applications. They are also applied successfully in other industry segments.

HCT products are encapsulated in solid flame resistant material for maximum durability, electrical integrity and complete environmental security.

HCT is a market leader in many application arenas, including hydraulic generator, *e-Fan* and hydraulic fan system controls. These controllers facilitate significant fuel, emission and operational savings.

HCT's market neutrality offers integration with any hydraulic OEM valves, pumps, sub-systems or systems.

For more information, please visit us at: www.hctcontrols.com.

Product Use Limitations

HCT products may not be suited for any of the following applications:

- Any product which comes under the Federal Highway Safety Act, namely steering or braking systems for passenger-carrying vehicles or on-highway trucks.
- Aircraft or space vehicles.
- Ordinance or military equipment.
- Life support equipment.
- Any end product which, when sold, comes under U.S. Nuclear Regulatory Commission rules and regulations.

HCT does not have any performance assurance programs for testing their products for the above applications.

HCT's products are not designed for these applications and HCT does not warrant, recommend, or specifically approve its products for these applications.

The user shall be solely responsible for any loss or damages occasioned by breach of the provisions of this paragraph and shall carry product liability and liability insurance to insure against such loss or damages.

Cautions

Changing setup values or operating modes while a machine is running may cause unintended machine movement. It could lead to possible **injury** or **death**. Any moving parts should be disabled prior to changing setup values or operating modes. In every case, exercise caution and work should be completed only by qualified personnel.

Product Application Guidelines

ALWAYS do the following

- FULLY read this manual and accompanying data sheets BEFORE starting.
- Isolate this unit from all other equipment BEFORE any form of welding.
- Isolate the controller from ANY form of battery charging or battery boosting.
- Be aware of the electrical & mechanical connections, and the expected reactions of the equipment.
- Operate the units within the temperature range.
- Use the correct tools to do the job (i.e. P.C., software) etc.
- Separate High Voltage AC cables from Low Voltage DC signal and supply cables.
- Make sure power supply is CORRECT, ELECTRICALLY CLEAN, STABLE, and rated for the full load.
- Make sure the controller output voltage & current is compatible with the equipment.
- All unused wires / terminals should be terminated safely.
- Ensure ALL connectors have no unintended SHORT or OPEN circuits.
- Ensure ALL connectors are wired correctly, secure, locked in place and fully connected.
- Disconnect or connect wires to or from this unit only when the power supply is disconnected.
- Use adequate screening in areas of intense Radio Frequency fields.
- Ensure ALL work areas are clear of personnel before operating the controller.
- Follow and abide by local and country health & safety standards.

MVP-R Ramping Controller

The MVP-R controller drives proportional solenoid valves with adjustable ramp times.

Once configured, the settings are permanently stored in the controller memory.

MVP-R Features

- Easily configured using HCT Graphical User Interface (GUI) or HCT Hand Held Interface (HHI)
- LED indication of power, output current and fault status
- Permanently sealed, standard DIN 43650 Form A connector body with pre-wired 18AWG PVC cable
- Single coil applications, programmable enable input
- Output limits are independently adjustable
- Adjustable output with short circuit protection
- Adjustable ramp up and ramp down times (RP1 has ramp up only)

Operating Specifications

Supply Voltage	9 to 32VDC		
Supply Current	Valve current + 20mA (Quiescent Max)		
Output Current	-06A: 600mA MAX	-12A: 1.2A MAX	-25A: 2.5A MAX
Coil Resistance	2Ω MIN.		
Dither Frequency	80, 100, 120, 140, 160, 180, 200, 220, 240, 260, 280, 300. (Select OFF for 1000Hz)		
Ramp Functions	-RP1: ramp up only	-RP2: ramp up and down	
Enable Input Voltage (RP2)	9 to 32VDC		
Operating Temperature Range	-40° to 85° C (operating); -60° to 90° C (storage)		
Enclosure	33% glass reinforced, heat stabilized, black polyamide 66		
Dimensions	Inch: 2.4 L x 1.2 W x 0.75 H; Mm: 60 L x 30 W x 19 H		
NEMA/IP Rating	NEMA 4 / IP67		



Physical Description

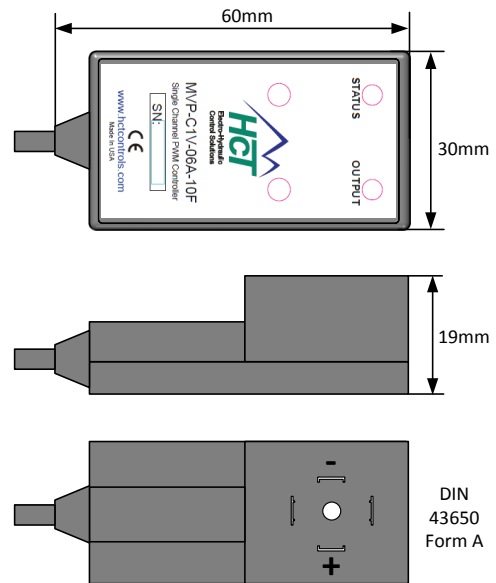

There are two indicator LEDs: STATUS and OUTPUT. The STATUS LED is green when the applied voltage is within the operating range.

The OUTPUT LED is yellow and the brightness will vary with the output current.

In the case of a fault the STATUS LED will flash red with a flash code. See Fault Status for details.

The MVP communicates with the Graphical User Interface through an infrared interface port to RS232. The infrared adapter clips onto the MVP-R aligning with the notches in the sides. It must be powered when configuring the settings.

User Interface

The MVP has a number of internal settings.

Users can open the Graphical User Interface to view, make changes and save the settings in a data file, which can be uploaded to any MVP controller.

The users can use the Hand Held Interface to view and make changes, but can not save the settings in a data file. The programmer, cable and adapter are self-contained which makes HHI a viable alternative for field work.

Configuration

The GUI has 4 buttons: Lock, Unlock, Up, and Down. There are short-cut keys: '/'(lock), '*'(unlock), '+'(up), and '-'(down).

The HCT Hand Held Interface has the same 4 buttons and a 2-line LCD display.



Use the up and down arrows to navigate through the parameter list. The display will show the next parameter in the list when pressed. The parameter name is on the first line and the value is on the second line. The list scrolls, stepping down from the last parameter to the first and vice-versa.

There are three types of parameters: **fixed**; **monitor**; and **variable**. **Fixed** parameters show the module's firmware version, etc. **Monitor** parameters display output current and system voltage. Use **variable** parameters to configure the controller, such as maximum output current, operating mode, etc. Some parameters combine variable and monitor in one line. Use it to set a variable according to the current monitor value.

Press the unlock button to enter the edit mode. An asterisk (*) will appear at the beginning of the second line. Use the up and down buttons to change the value. For parameters containing both variable and monitor, the monitor data is in square brackets.

Press the lock button to save the parameters and end edit mode.

When the lock button is pressed, the changes take effect immediately. Change values only when the machine is **NOT** running.

“Read settings from controller” displays a static table of values from non-volatile memory. The changes made to the settings by selecting “lock” are not updated in the table unless “read settings from controller” is selected again.

To save the settings into a file for future use, click “read settings from controller” before clicking “save settings to file”.

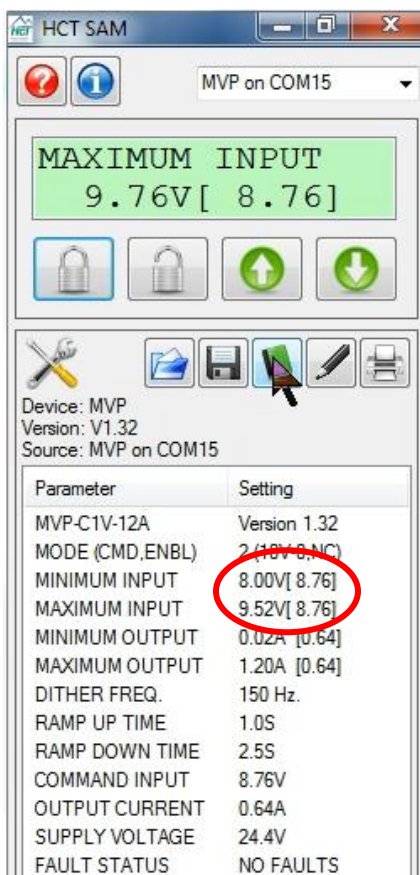

MAXIMUM INPUT
9.76V [8.76]

Parameter	Setting
MVP-C1V-12A	Version 1.32
MODE (CMD,ENBL)	2 (10V 0 NC)
MINIMUM INPUT	8.00V [8.76]
MAXIMUM INPUT	9.52V [8.76]
MINIMUM OUTPUT	0.02A [0.64]
MAXIMUM OUTPUT	1.20A [0.64]
DITHER FREQ.	150 Hz.
RAMP UP TIME	1.0S
RAMP DOWN TIME	2.5S
COMMAND INPUT	8.76V
OUTPUT CURRENT	0.64A
SUPPLY VOLTAGE	24.4V
FAULT STATUS	NO FAULTS

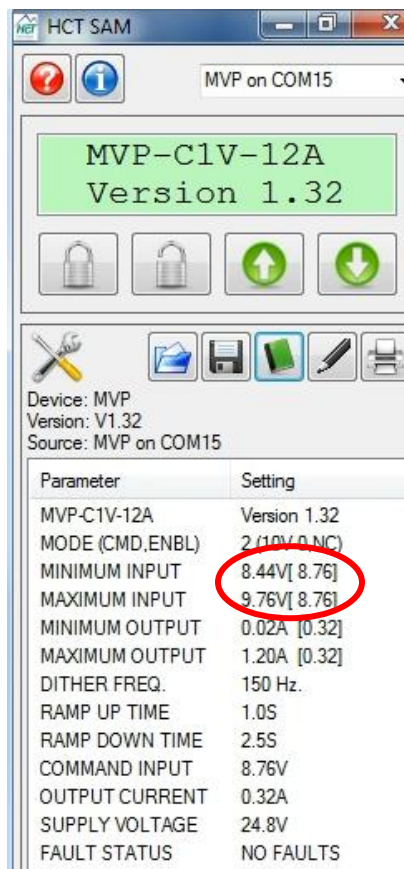

MVP-C1V-12A
Version 1.32

Parameter	Setting
MVP-C1V-12A	Version 1.32
MODE (CMD,ENBL)	2 (10V 0 NC)
MINIMUM INPUT	8.44V [8.76]
MAXIMUM INPUT	9.76V [8.76]
MINIMUM OUTPUT	0.02A [0.32]
MAXIMUM OUTPUT	1.20A [0.32]
DITHER FREQ.	150 Hz.
RAMP UP TIME	1.0S
RAMP DOWN TIME	2.5S
COMMAND INPUT	8.76V
OUTPUT CURRENT	0.32A
SUPPLY VOLTAGE	24.8V
FAULT STATUS	NO FAULTS

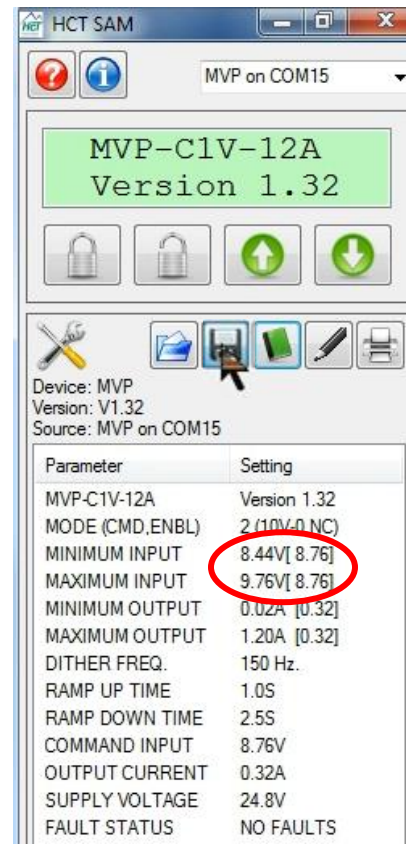

MVP-C1V-12A
Version 1.32

Parameter	Setting
MVP-C1V-12A	Version 1.32
MODE (CMD,ENBL)	2 (10V 0 NC)
MINIMUM INPUT	8.44V [8.76]
MAXIMUM INPUT	9.76V [8.76]
MINIMUM OUTPUT	0.02A [0.32]
MAXIMUM OUTPUT	1.20A [0.32]
DITHER FREQ.	150 Hz.
RAMP UP TIME	1.0S
RAMP DOWN TIME	2.5S
COMMAND INPUT	8.76V
OUTPUT CURRENT	0.32A
SUPPLY VOLTAGE	24.8V
FAULT STATUS	NO FAULTS

When uploading settings from a data file, the static table shows the settings from the data file, but they are not in the controller yet.

Click “write settings to controller” before clicking “read settings from controller”. After this step, the static table will display the MVP settings from the data file.

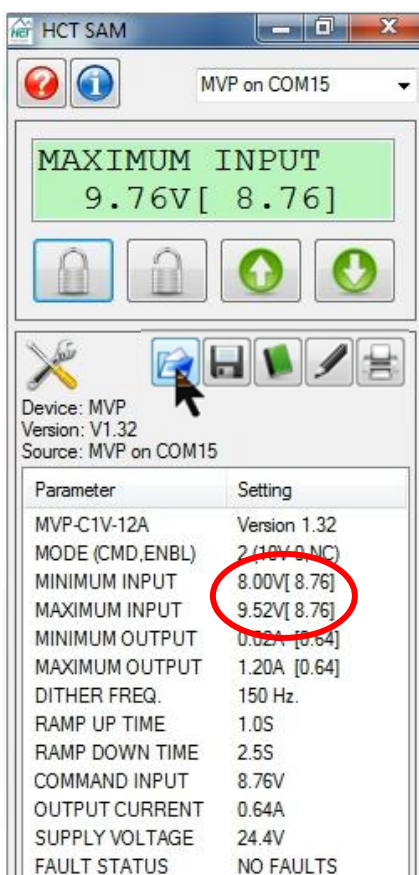

Device: MVP
Version: V1.32
Source: MVP on COM15

Parameter	Setting
MVP-C1V-12A	Version 1.32
MODE (CMD,ENBL)	2 (10V/0 NC)
MINIMUM INPUT	8.00V [8.76]
MAXIMUM INPUT	9.52V [8.76]
MINIMUM OUTPUT	0.02A [0.32]
MAXIMUM OUTPUT	1.20A [0.64]
DITHER FREQ.	150 Hz.
RAMP UP TIME	1.0S
RAMP DOWN TIME	2.5S
COMMAND INPUT	8.76V
OUTPUT CURRENT	0.64A
SUPPLY VOLTAGE	24.4V
FAULT STATUS	NO FAULTS

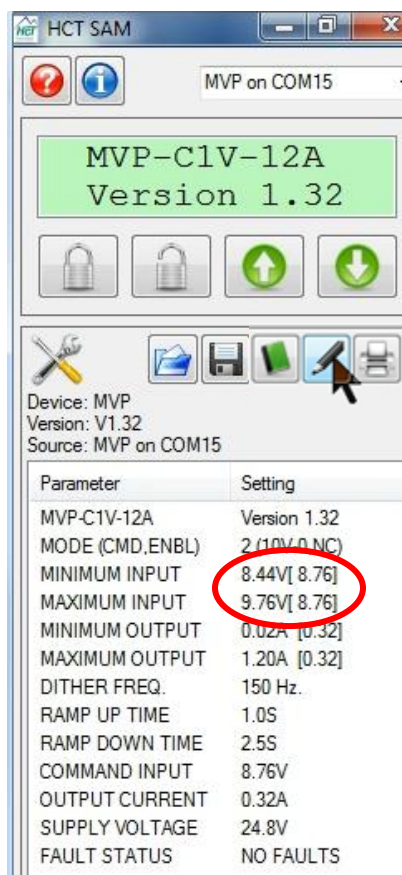

Device: MVP
Version: V1.32
Source: MVP on COM15

Parameter	Setting
MVP-C1V-12A	Version 1.32
MODE (CMD,ENBL)	2 (10V/0 NC)
MINIMUM INPUT	8.44V [8.76]
MAXIMUM INPUT	9.76V [8.76]
MINIMUM OUTPUT	0.02A [0.32]
MAXIMUM OUTPUT	1.20A [0.32]
DITHER FREQ.	150 Hz.
RAMP UP TIME	1.0S
RAMP DOWN TIME	2.5S
COMMAND INPUT	8.76V
OUTPUT CURRENT	0.32A
SUPPLY VOLTAGE	24.8V
FAULT STATUS	NO FAULTS

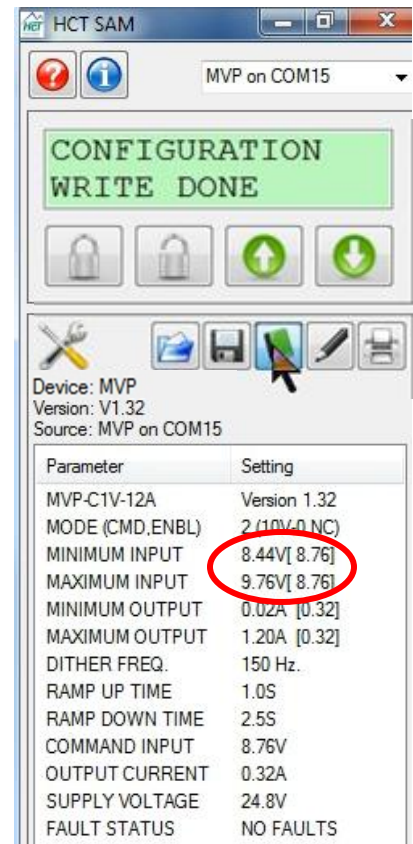

Device: MVP
Version: V1.32
Source: MVP on COM15

Parameter	Setting
MVP-C1V-12A	Version 1.32
MODE (CMD,ENBL)	2 (10V/0 NC)
MINIMUM INPUT	8.44V [8.76]
MAXIMUM INPUT	9.76V [8.76]
MINIMUM OUTPUT	0.02A [0.32]
MAXIMUM OUTPUT	1.20A [0.32]
DITHER FREQ.	150 Hz.
RAMP UP TIME	1.0S
RAMP DOWN TIME	2.5S
COMMAND INPUT	8.76V
OUTPUT CURRENT	0.32A
SUPPLY VOLTAGE	24.8V
FAULT STATUS	NO FAULTS

Parameter List

The following table outlines the MVP-R parameters as well as the limits and units of measure for each parameter.

Parameter	Limits	Units
MVP-RPx-xxx		Version #
Ramp time factor	X1, /10	Mode #
Ramp up time	0.0 to 120.0	Seconds
Ramp down time*	0.0 to 120.0	Seconds
Minimum output	0 to 600**	mA
Maximum output	0 to 600**	mA
Dither frequency	80 to 300, (select OFF for 1000Hz)	Hz.
Output current		mA
Supply voltage		Volts
Fault status		Fault

*RP2 only

0 to 1.2A for **-12A version, 0 to 2.5A for **-25A** version

MVP-RPx-xxx	The title parameter is fixed. It displays the model number and the firmware version.
RAMP TIME FACTOR	Sets the rate of change for the output current. If the Ramp Time Factor is x1, the ramp time will match the ramp time settings. If it is set to 1/10, the ramp time will be 1/10 of the ramp time setting.
RAMP UP/DOWN TIME	<p>Sets the rate of change for Output current.</p> <p>For RP1, the output current increases from Minimum to Maximum.</p> <p>For RP2, the output current is initially set to the Minimum.</p> <ul style="list-style-type: none">• The output current increases from Minimum to Maximum within the Ramp Up time when switching ON “ENABLE” switch.• The output current decreases from Maximum to Minimum within the Ramp Down time when switching OFF “ENABLE” switch.
MIN OUTPUT	Sets the minimum output current (milliamps, amps for -12A,-25A). The value in the brackets is the present output current.
MAX OUTPUT	Sets the maximum output current (milliamps, amps for -12A,-25A). The value in the brackets is the present output current.
DITHER FREQ.	Options: 80, 100, 120, 140, 160, 180, 200, 220, 240, 260, 280, 300, (Select OFF for 1000Hz). Set the PWM or dither frequency according to the valve specifications. This parameter is variable.
OUTPUT CURRENT	Displays the present output current. This parameter is a monitor type.
SUPPLY VOLTAGE	Displays the module’s power supply voltage. It is helpful for troubleshooting. This parameter is a monitor type.
FAULT STATUS	The STATUS LED will flash red 2 times for Coil Open and 3 times for Coil Short.

Wiring

MVP-RP1 Wiring	
Terminal	Function
Brown	PWR
Blue	PWR GND
GRN/YEL	Connector GND

MVP-RP2 Wiring	
Terminal	Function
Brown	PWR
Blue	PWR GND
Black	Enable Input
White	Not Used
Red	Not Used
GRN/YEL	Connector GND

Order Information

MVP-RP1-06A-10F

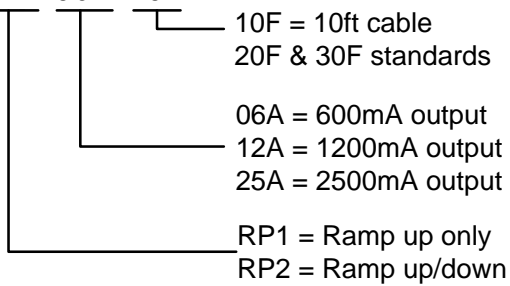

For the Hand Held Interface Device: P/N: CBL-IRA



For the PC software SAM: PN: CBL-IRMU



Application Examples

Single Solenoid Control

The MVP can drive a single solenoid.

Set the dither and output settings according to the valve specifications.

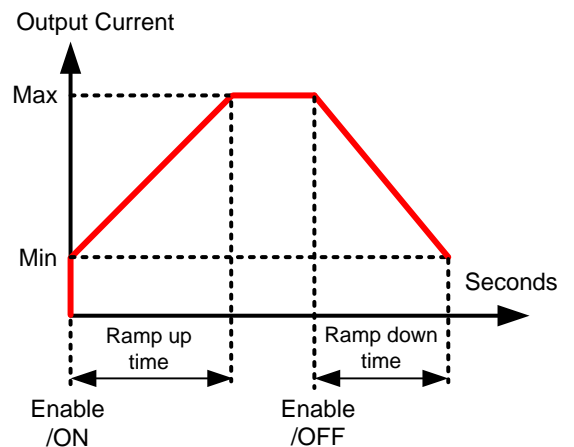
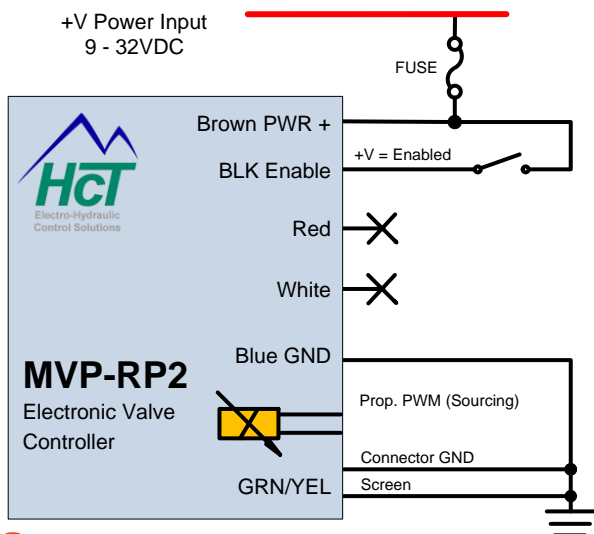
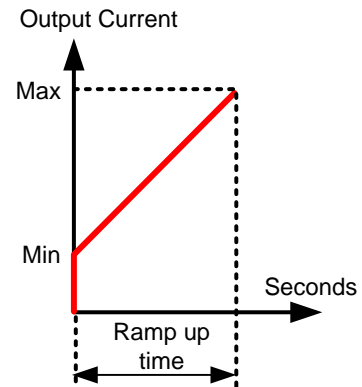
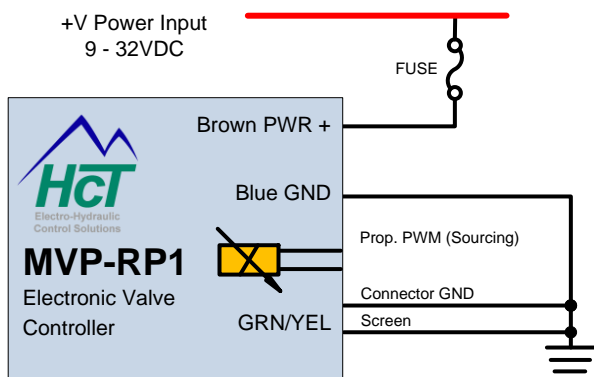

- ❖ Mining & Exploration
- ❖ Agriculture
- ❖ Cranes & lifts
- ❖ Refuse & Re-cycling
- ❖ Construction
- ❖ Off-Road vehicles
- ❖ Forestry, Wood & Pulp
- ❖ Reclamation & Salvage
- ❖ Oil Field & Sands
- ❖ Demolition Equipment
- ❖ Cooling Solutions
- ❖ Military Apparatus
- ❖ Specialty Use
- ❖ Remote Control
- ❖ Power Generation
- ❖ Emission Controls
- ❖ Integrated Drivers
- ❖ Valve & Pump Controls



HCT Product Sales and Support:

For a full list of authorized distributors worldwide, please visit:
www.hctcontrols.com/distributors/index.htm

Need More Information ?

For customer service, pricing, order placement and application support, contact us through E-mail at:
info@hctcontrols.com

www.hctcontrols.com



High Country Tek, Inc.
 208 Gold Flat Court
 Nevada City, CA, 95959
 Tel: (1) 530 265 3236
 Fax: (1) 530 265 3275

