

Enclosed SM2 250 Range of Automatic Battery Chargers



Description

The SM2 250 is a highly efficient high performance charger. The very smooth output is configured for accurate fast charging and optimum battery life and reliability. The charger is designed to cater for continuous float charging and standby battery applications. Due to its very smooth output (< 1% ripple) the charger is suitable for sealed or vented batteries. e.g. Nickel Cadmium (NiCd), Lead acid, sealed and vented, and Plante cells. The wide input voltage range, from 95-277VAC allows the charger to be used with all common single phase voltages with no adjustment. Switch mode technology is a major advance in power supply and battery charger design. Giving low heat dissipation compact low weight design and ease of panel installation via din rail. Utilising the benefits of switch mode, the charger will give a constant current output up to its knee point (13 Volts on 12 Volt LA) and then ramp down to its float voltage (see graph below). This gives the optimum charge time to ensure that the battery voltage is maintained at the pre-calibrated float level, whilst supplying any additional standing load current up to a specified maximum.

Charging current vs voltage

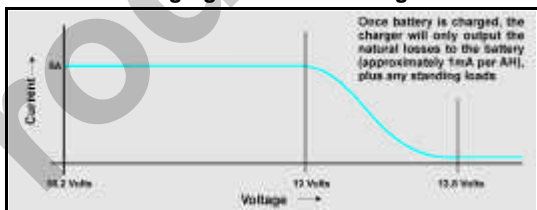

Boost option

A 'boost' mode of operation provides increased voltage output. Selection of boost mode is via two terminations, allowing activation by a time delay relay or switch. A calibration table overleaf shows details of float and boost voltages.

Charge fail relay

A self diagnostic 'charge fail' circuit and relay output is provided as standard. The volt free relay de-energises in the event of a charging fault.

Electrical connection of the AC supply, DC output and charge fail relay are via spring clamp terminals.

- **High rate duty float charging:**
17A @ 12V - 9A @ 24V - 6A @ 36V - 4.5A @ 48V
- **Fully automatic charge regulation**
- **Stainless steel enclosure with ammeter indication**
- **Charge fail relay output**
- **Optional boost mode**

Product Specification

Power Supply:

nominal operating voltages	95-277VAC
nominal operating frequency	47-400Hz

DC Charge Output:

output current ADC	9	17
nominal voltage VDC	24	12
line regulation	< 1%	
load regulation	< 1%	
output ripple	< 1%	
float / boost voltages	see table overleaf	

Charge Fail Output:

relay type	volt free SPDT contacts relay de-energised on fault
contact rating	1A @ 30VDC (resistive load)

General:

operating temperature	-10 to +55°C
overall dimensions (w x h x d)	140mm x 270mm x 115mm (5.5" x 10.6" x 4.5")
weight	0.8Kg (1.7lbs)
EMC emission / immunity	EN 58801-2 / EN50082-2

Warranty

A one year limited warranty on materials and workmanship is given with this product. Details are available upon request.

Electrical connection

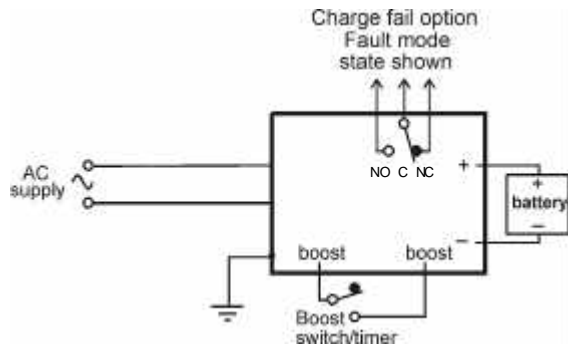

Notes:

- 1) battery output is isolated from chassis
- 2) chassis must be connected to a low impedance earth

Calibration

Battery type		float volts (VDC)	boost volts (VDC)
12V	Lead Acid (6 cells)	13.6	14.1
	Ni-Cd (10 cells)	14.1	16.0
24V	Lead Acid (12 Cells)	27.2	28.2
	Ni-Cd (18 Cells)	25.38	28.8
	Ni-Cd (20 Cells)	28.2	32.0

The above are factory standard settings, specials are available on request.

Dimensions

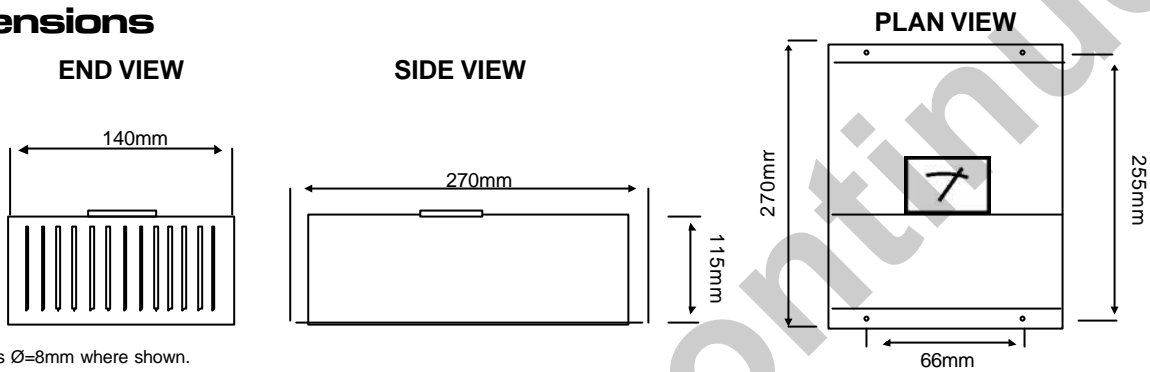

Fixing holes $\varnothing=8\text{mm}$ where shown.

How to order

When ordering, please specify:-

PRODUCT	Nominal Output VDC				Nominal Output Current			
	12	24	36	48	17	9	6	4.5
ESM22501217	•				•			
ESM2250249		•				•		
ESM2250366			•				•	
ESM2250484.5				•				•

INPUT VOLTAGE	
CODE	95-277VAC
CD	•

	BATTERY TYPE			
	Lead Acid	10 Cell Ni Cad	18 Cell Ni Cad	20 Cell Ni Cad
LA	•			
10		•		
18			•	
20				•

	OPTIONS	
	Manual Boost	Output Inhibit
MB	•	
OI		•

Product	Input volts	Battery type	Options	Options
ESM22501217	CD	LA	MB	OI

The above 3 part number codes must be filled in to complete your order.

Insert options when required, if no options are required, leave empty.

ESM22501217

CD

LA

MB

The above example shows the order code for an enclosed 95-277V, AC input, 12V@17A, DC output charger, calibrated for a vented lead acid battery, and with manual boost option.

Computronic Controls Ltd
 41 - 46 Railway Terrace
 Nechells, Birmingham, B7 5NG
 United Kingdom
 Tel +44 121 327 8500
 Fax +44 121 327 8501
 email: sales@computroniccontrols.com
 web: www.computroniccontrols.com