



POWERVIEW

- For Modern Electronic Engines and Equipment Applications Using SAE J1939 Controller Area Network
- Displays Over 30 Standard SAE J1939 Parameters Broadcast by Engine and Transmission ECU's
- Graphical Display Features Wide Operating Temperature Range Viewing (-40 to 167°F/75°C).
- Displays Active and ECU-Stored Faults with Text Description for Diagnosing Equipment Malfunctions
- Simple Connection to Optional Components

Description

The PowerView is a powerful new display in a line of components manufactured by FWMurphy as part of its J1939 MurphyLink™ Family. The J1939 MurphyLink™ Family of products has been developed to meet the needs for instrumentation and control on electronically controlled engines communicating using the SAE J1939 Controller Area Network (CAN).

The PowerView System is comprised of the PowerView and the MLink™ PowerView Analog Gages. The PowerView is a multifunction tool that enables equipment operators to view many different engine or transmission parameters and service codes. The system provides a window into modern electronic engines and transmissions. The PowerView includes a graphical backlit LCD screen. Back lighting can be controlled via menu or external dimmer potentiometer. The display can show either a single parameter or a quadrant display showing four parameters simultaneously. Diagnostic capabilities include fault codes with text translation for the most common fault conditions.

The PowerView has four buttons using touch sensitive technology, which eliminates the concern for push button wear and failure. In addition, operators can navigate the display with ease. The enhanced alarm indication has ultra-bright alarm and shutdown LEDs (amber and red). It has a wide operating temperature range of -40 to 185°F (-40 to +85°C), display viewing -40 to 167°F (-40 to +75°C), and environmental sealing to +/-5 PSI (±34 kPa). In addition the PowerView features Deutsch DT style connectors molded into the casing and fits quickly and easily into existing 2-1/16 in. (52 mm) diameter gage openings.

Other components in the system are micro-processor-based MLink™ PowerView Analog Gages for displaying critical engine data broadcast by an electronic engine or transmission's Engine Control Unit (ECU): engine RPM, oil pressure, coolant temperature, system voltage, etc. and a combination audible alarm and relay unit for warning and shutdown annunciation. Up to 32 components may be linked to the PowerView using a simple daisy chain wire connection scheme using RS485. The PowerView and all connected components can be powered by either 12 or 24-volt systems.

Display Parameters

The following are some of the engine and transmission parameters displayed by the PowerView in English or Metric units as well as in Spanish, French, or German (when applicable, consult engine or transmission manufacturer for SAE J1939 supported parameters):

- Engine RPM
- Engine Hours
- Machine Hours
- System Voltage
- % Engine Load at the Current RPM
- Coolant Temperature
- Oil Pressure
- Fuel Economy
- Throttle Position
- Engine Manifold Air Temperature
- Current Fuel Consumption
- Transmission Oil Pressure
- Transmission Oil Temperature
- Transmission Gear Position
- Active Service Codes
- Stored Service Codes (when supported)
- Set Units for Display (English or Metric)
- View Engine Configuration Parameters

Specifications

- Display:** 1.3 x 2.6 in. (33 x 66 mm), 64 x 128 pixels.
- Operating Voltage:** 8 VDC minimum to 32 VDC max.
- Reversed Polarity:** Withstands reversed battery terminal polarity indefinitely within operating temperatures.
- Operating Temperature:** -40 to +85°C (-40 to 185°F).
- Display Viewing Temperature:** -40 to +75°C (-40 to 167°F).
- Storage Temperature:** -40 to +85°C (-40 to 185°F).
- Environmental Sealing:** IP68, +/- 5 PSI (+/- 34.4 kPa).
- Power Supply Operating Current:** (@ 14 VDC)= 52 mA minimum; 268 mA maximum (LCD heater on).
- CAN BUS:** SAE J1939 Compliant.
- Case:** Polycarbonate / Polyester.
- Clamp:** Polyester (PBT).
- Connectors:** 6-Pin Deutsch DTO6 Series.
- Maximum Panel Thickness:** 3/8 in. (9.6 mm).
- Mounting Hole:** 2.062 inch (52 mm) in diameter.
- Auxiliary Communications: Either:**
Gages: One (1) RS485 port, MODBUS RTU master.
MODBUS: One (1) RS485 port, MODBUS RTU slave, selectable baud rate; 9800; 27K; 38.4K.
- Potentiometer (External Dimmer) Input:** 1K ohm, 1/4 W
- Shipping Weights (all models):** 1/2 lb. (225 g.)
- Shipping Dimensions (all models):** 6 x 6 x 6 in. (152 x 152 x 152 mm).

Warranty

A limited warranty on materials and workmanship is given with this FW Murphy product. A copy of the warranty may be viewed or printed by going to www.fwmurphy.com/support/warranty.htm

Accessories

- PowerView Analog Gages
 - PowerView Wiring Harnesses
- For details see bulletin PVC-03020B*

† *MurphyLink™ is a registered trademark of FWMurphy. All other trademarks and service marks used in this document are the property of their respective owners.*

Dimensions

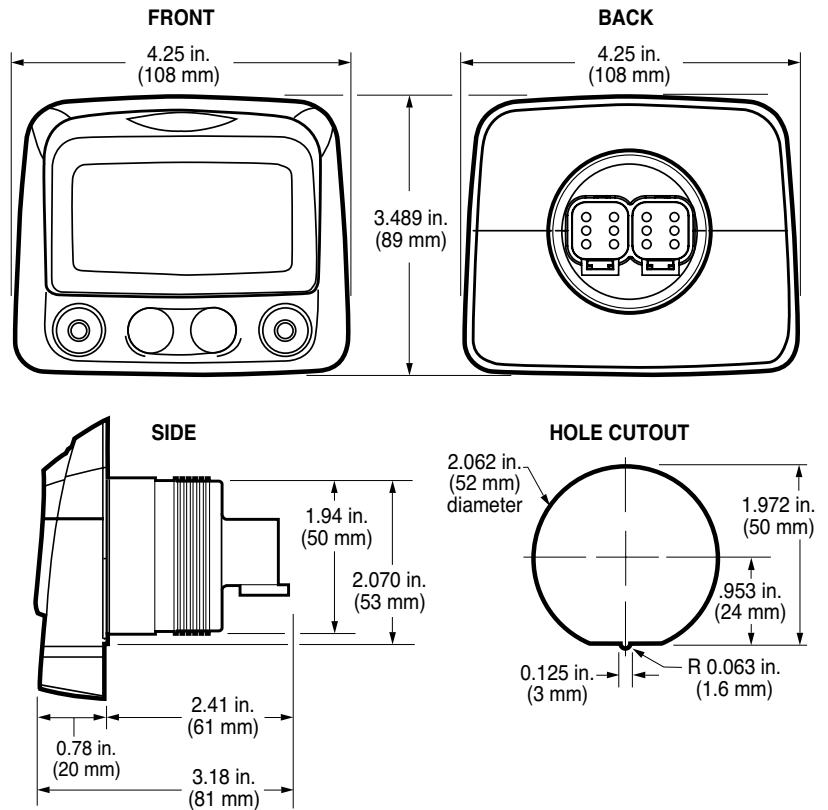

How to Order

To order the PowerView use the model number designation diagram below.

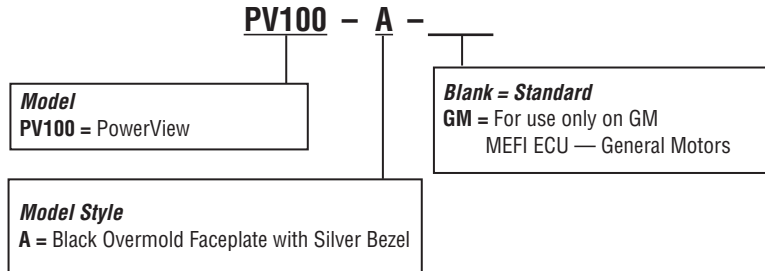

MURPHY

FW Murphy
P.O. Box 470248
Tulsa, Oklahoma 74147 USA
+1 918 317 4100
fax +1 918 317 4266
e-mail sales@fwmurphy.com
www.fwmurphy.com

CONTROL SYSTEMS & SERVICES DIVISION
P.O. Box 1819; Rosenberg, Texas 77471; USA
+1 281 633 4500 **fax** +1 281 633 4588
e-mail sales@fwmurphy.com

MURPHY DE MEXICO, S.A. DE C.V.
Blvd. Antonio Rocha Cordero 300, Fracción del Aguaje
San Luis Potosí, S.L.P.; México 78384
+52 444 8206264 **fax** +52 444 8206336
Villahermosa Office +52 993 3162117
e-mail ventas@murphymex.com.mx
www.murphymex.com

FRANK W. MURPHY, LTD.
Church Rd.; Laverstock, Salisbury SP1 1QZ; U.K.
+44 1722 410055 **fax** +44 1722 410088
e-mail sales@fwmurphy.co.uk
www.fwmurphy.co.uk

MURPHY SWITCH OF CALIFORNIA
41343 12th Street West
Palmdale, California 93551-1442; USA
+1 661 272 4700 **fax** +1 661 947 7570
e-mail sales@murphyswitch.com
www.murphyswitch.com

MACQUARRIE CORPORATION
1620 Hume Highway
Campbellfield, Vic 3061; Australia
+61 3 9358 5555 **fax** +61 3 9358 5558
e-mail murphy@macquarrie.com.au



In order to consistently bring you the highest quality, full featured products, we reserve the right to change our specifications and designs at any time.