

# Rack Puller for Diesel Engines

## Model RP75

The RP75 Rack Puller is a semiautomatic device that provides a pulling force to initiate shut down of diesel engines and equipment.

The RP75 connects to the injection pump or air intake shut-off lever via a cable (chain optional). A coil spring, within the RP75, is reset manually and is held in place by an electromagnet. When the Swichgage® detects a malfunction, the electromagnetic circuit is interrupted through a magnetic switch — releasing the coil spring thus pulling the cable/chain to actuate shutdown. When fully compressed, the spring exerts a pull of 30 lbf (133 N).

The RP75 is available for 12- or 24-VDC applications and is compatible with all Swichgage instruments.



### Dimensions

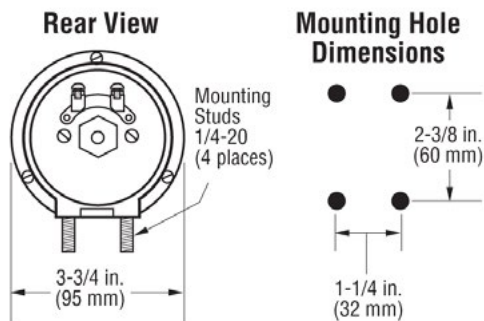
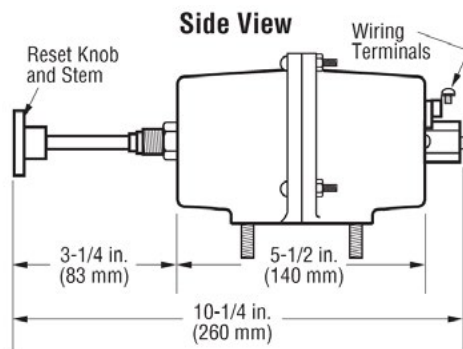

### Specifications

#### Operating Force:

30 lbf (133 N) maximum, 10 lbf (44 N) minimum

#### Coil Voltage:

Specify 12- or 24-VDC

#### Coil Resistance:

RP75-12: 32.2 ohms; RP75-24: 129.8 ohms

#### Length of Travel:

1-7/8 in. (48 mm)

#### Control Linkage:

**Cable:** 4ft. (1.22 m); Optional 8 ft. (2.43 m) or 12 ft. (3.65 m) available

**Chain (optional):** 30 in. (762 mm)

#### Shipping Weight:

5 lbs 3 oz. (2.4 kg)

#### Shipping Dimensions:

9-1/4 x 8-1/4 x 5-1/4 in. (235 x 210 x 133 mm)

# Installation



## WARNING Before beginning installation of this Murphy product:

- Disconnect ALL electrical power to the machine.
- Make sure the machine CANNOT operate during installation.
- Follow all safety warnings of the machine manufacturer.
- Read and follow all installation instructions.

## Mounting

1. Mount the RP75 using the 40-05-0161 mounting bracket or similar (see Figure 1). If installing the RP75 to an engine compartment firewall, go to Step 2.

2. If installing the RP75 to an engine compartment firewall, drill a 37/64 in. (15 mm) diameter hole in the firewall (see Figure 2).

3. Remove the reset knob on the RP75 by loosening the Allen-head screw on the knob.

4. Remove the mounting nut and insert the RP75 reset stem through the hole from the back of the firewall.

5. Replace the mounting nut and tighten. Reinstall the reset knob.

## Typical Wiring Diagrams

Wire the RP75 appropriately (see Figure 3).

**NOTE:** RP75 is voltage rated; do not apply 24-VDC to 12-VDC model and vice versa. Also, the 117PH Magnetic Switch is rated for both 12- and 24-VDC circuits but voltage must be specified when ordering the 518PH or 761APH Magnetic Switches.

## Installing Cable or Chain

1. To install the control linkage (cable or chain), apply voltage to the RP75. Push in the reset knob. If installing the cable, insert the cable attaching nut into the RP75 and tighten snugly (see Figure 1). DO NOT OVER TIGHTEN or threads may strip. Attach and tighten outer cable securing nut. If installing the chain, attach the S hook to the RP75 (see Figure 1).

2. Attach the other end of the cable or chain to the injection pump or air intake shutoff lever so it moves freely without sharp bends and without binding.

## Operation Test

**NOTE:** Some method must be provided to disconnect (lockout) all normally closed Swichgagge® circuits when starting (such as through the appropriate Magnetic Switch).

1. Reset magnetic switch.
2. Push in RP75 reset stem until coil latches the trip mechanism.
3. Start engine and observe that all locked out contacts clear.

4. With engine running, ground Swichgagge contact. The Magnetic Switch will trip thus removing voltage to RP75. The engine should shutdown immediately. If the engine does shutdown, adjust control linkage (cable or chain) to ensure that shutoff lever travels the full length in both directions.



**WARNING: The firewall must be capable of withstanding the push and pull force of the RP75.**

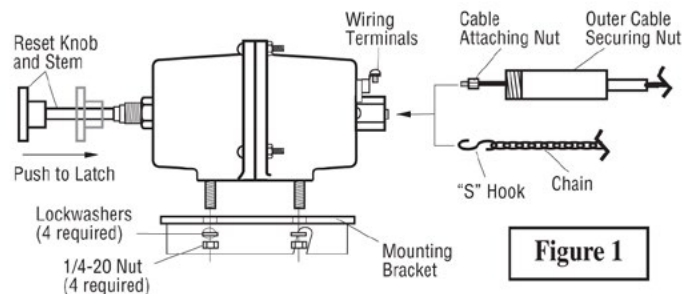

Figure 1

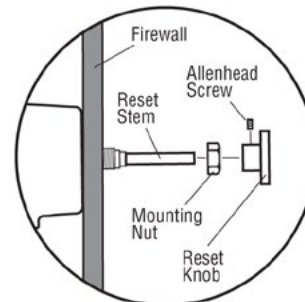

Figure 2

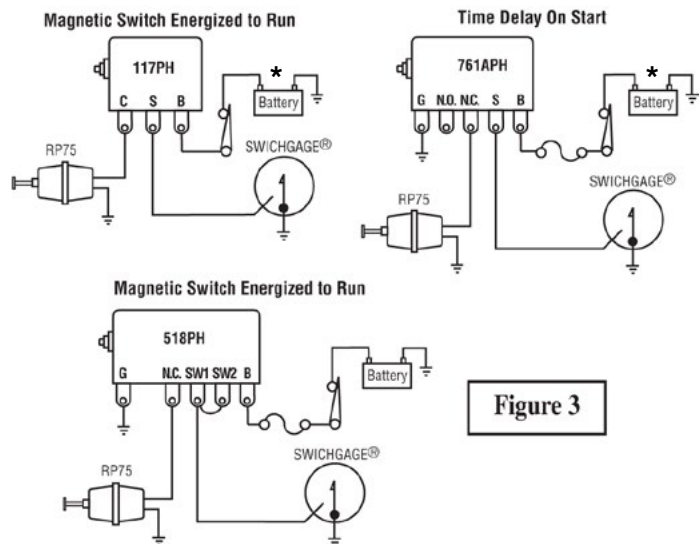

Figure 3

\* Always provide proper circuit protection with fuses or circuit breakers.



**CAUTION: Shut-off lever should not pull hard against the stop in the OFF position.**

## How to Order

Options listed below. All configurations may not be available. Call your sales representative or Enovation Controls for more information.

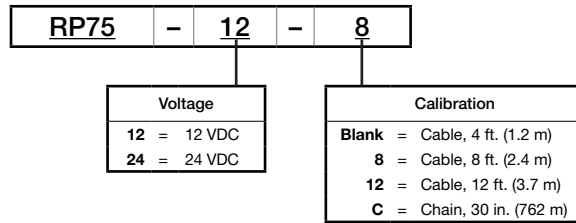

Part Number	Description	Notes
40050161	Mounting Bracket	Mounting bracket is sold separately from RP75.
40000021	12 VDC core assembly	Service parts
40000044	Shaft solenoid assembly	
40010050	Bushing shaft assembly	
40010053	Case repair kit	
40040054	Cocking rod, bushing and knob repair kit	
40050136	Spring, main actuating	
40050149	Spring, cocking rod return	
80041030	2 screw, machined #10-24 x 3/8 pan HD steel CAD II	
40000024	24 VDC core assembly	

This Page Has Intentionally Been Left Blank