

# Pressure Transmitters

## PXT-K Series

The PXT-K Series pressure transmitters are state-of-the-art instruments providing 4-20 mA output. Each Piezoresistive Pressure Transmitter contains a transducer comprised of a piezoresistive silicon chip mounted on a glass-metal feed-through header welded into a stainless steel housing and filled with silicone oil. The very thin laser-welded stainless steel isolation-diaphragm completes the front side. Media pressure is transferred from the stainless steel isolation-diaphragm via the oil inside the cell to the silicon measuring chip. This construction, combined with the advanced internal signal conditioning circuitry, results in a rugged instrument with extremely small temperature error and class-leading EMI/RFI resistance.

The enclosure and all wetted parts are made of 316L stainless steel to comply with NACE MR0175.

PXT-K Series Pressure Transmitters can be used in applications such as compressors, engines, process control, liquid level and pumps.

### Operating Range

Supply voltage for the PXT-K must be within range of 8-30 VDC. The graph below shows the minimum supply voltage (VDC) required for a given load resistance (R).

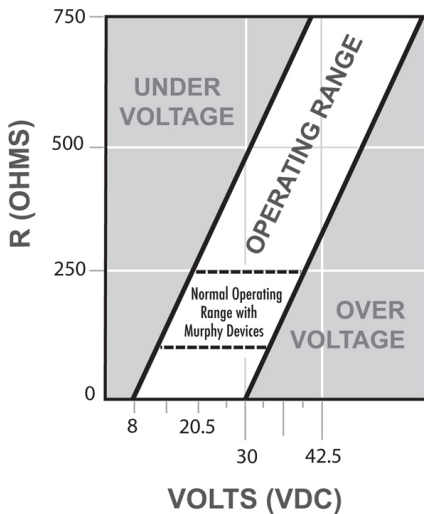

**LOOP RESISTANCE GRAPH**

#### Accuracy:

<b>% of Span (BFSL)</b>	+/- 0.25% of span*
<b>Zero/Span Setting Tolerance</b>	+/- 2.5% of full scale* max. (30V/30WC only)
	+/- 0.25% of span* typical,
	+/-0.5% of span* max (all other ranges)
<b>Operating Temperature</b>	+/- 2.5% of span T.E.B.
<b>Compensated Temperature</b>	+/- 1.7% of span T.E.B.
<b>Response Time</b>	<5mS

\* Accuracy Tolerance to be applied at 25°C.



### Specifications

**Operating Pressure Range:** See How to Order under the PXT-K Series Model Number Matrix.

**Operating Temperature:** -40 to 180° F (-40 to 82° C)

**Compensated Temp Range:** -20 to 160° F (-29 to 71° C)

#### Physical Characteristics

**Process Connection:** 1/4 NPT female with 7/8" Hex nut

**Electrical Connection (PXT-K-XXX):** 1/2" NPT male conduit connection with 60" long cable, vented

**Enclosure:** NEMA 4/IP65 or better

**Body:** 316L stainless steel. Complies with NACE MR0175

**Wetted Parts:** 316L stainless steel

**Environmental Effect (Humidity):** No effect for 0-95%, non-condensing

**Mounting:** Transmitter can be installed in any axis. Transmitter position has negligible effect on performance as long as it is perpendicular to the flow being monitored.

**Shock Resistance:** 1000g per IEC 60068-2-6 (Mechanical Shock)

**Vibration Resistance:** 20G per IEC 60068-2-6 (Vibration under resonance)

**Wiring Protection:** Protected against reverse polarity and short circuit, 48 VDC Maximum

**Supply Voltage:** 8 - 30 VDC (Typically 24 VDC)

**Transmitter Output:** 4-20mA, two wire configurations with load characteristics

**Insulation:** Greater than 10MΩ @ 300 VDC

**Electromagnetic Compatibility (EMC):** Standards; EN 61000-6-2:2005, EN 61000-6-3:2007, EN 61326-2-3:2006

**Voltage Surge/Spike Protection:** Protection against a 600 volt spike per IEC 60-2

**Shipping Weight:** 6.5 ounces

#### Applicable Standards

**NACE MR0175** Compliant with the requirements

**CSA (c/us):** Class I / II / III, Div 1, Groups A-F T4

Class I / II / III, Div 2, Groups A-D,F,G T4

**ATEX:** IBEU 10 ATEX 1124 X

II 1G Ex ia IIC T6-T4

II 3G Ex nA IIC T6

## PXT and PXT-K Series Transmitter Cabling Identification

The PXT Series Pressure Transmitters have been changed. Previous pressure transmitters in this series were identified as **PXT Pressure Transmitters**. The newest version is the **PXT-K Series Pressure Transmitters**. Identification of electrical cable color is NOT interchangeable between the two series of pressure transmitters.

This section contains information to assist you in identifying the pressure transmitter unit you have and the correct electrical cable colors to avoid wiring mistakes.

### PXT Series



### PXT-K Series

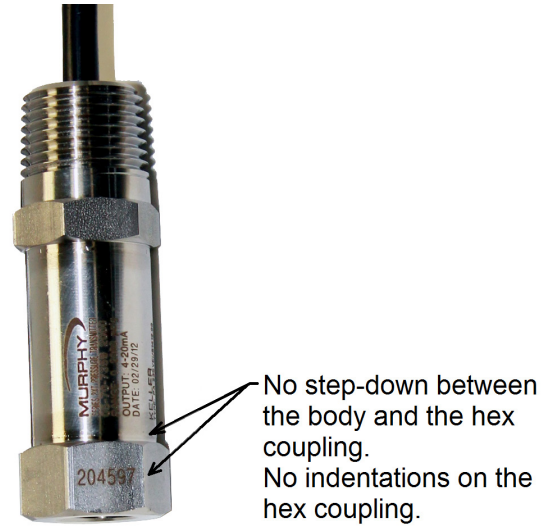

Cable Color	Connection	Cable Color	Connection
RED	POWER	RED	POWER
BLUE	SIGNAL	BLUE	N/A
BLACK	CASE GROUND	BLACK	SIGNAL
ORANGE, YELLOW, WHITE	N/A	ORANGE, YELLOW, WHITE	N/A
Installation Instructions	00020475	Installation Manual	00020840
Installation Diagram	05-08-0754	Installation Diagram	05-08-0763

Shield drain wire is isolated from case.

Shield drain wire is common to case.

## Dimensions

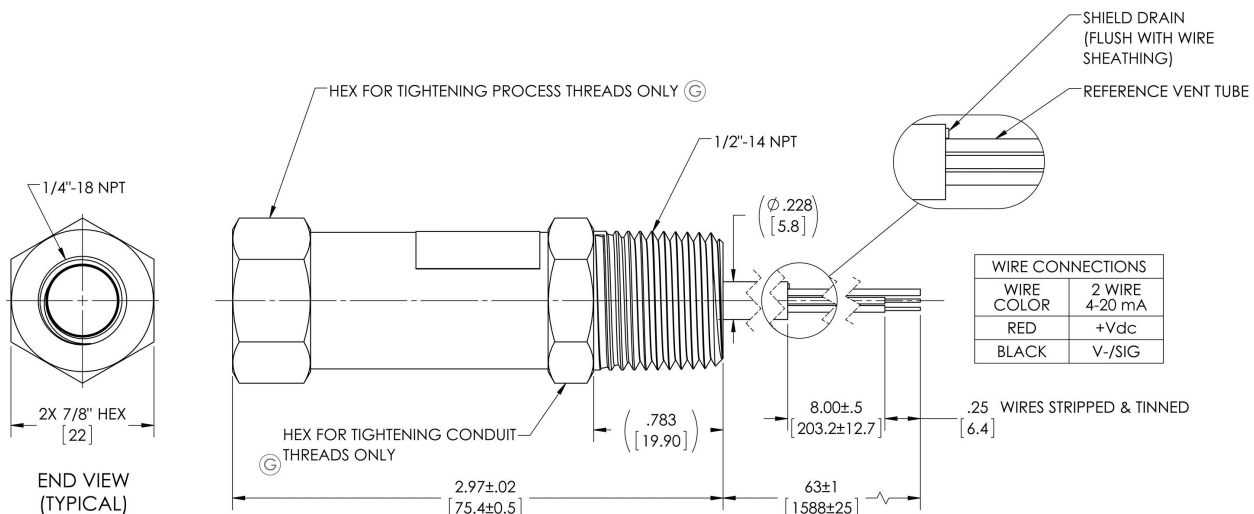

# How to Order

Options listed a right. All configurations may not be available. Call your sales representative or Enovation Controls for more information.

Murphy two wire Pressure Transmitter with Flying Lead Connection, 0-600psig range, 4-20 mAdc output. If no digit follows the pressure range, it is automatically a 4-20mAdc output signal.

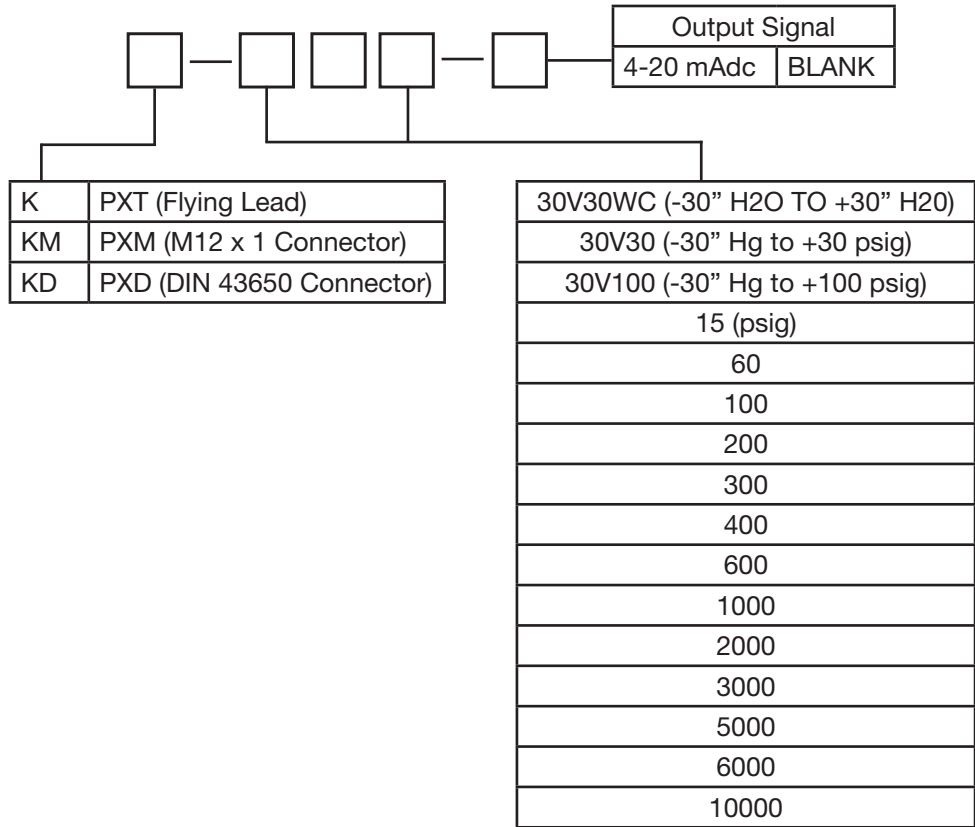

This Page Has Intentionally Been Left Blank